

USE AND MAINTENANCE MANUAL

 **FIMAP**[®]



SMG130 S BASIC

ED. 09-2012

EN

ORIGINAL
INSTRUCTIONS
Doc. 10036995
Ver. AA



The descriptions contained in this document are not binding.
The company therefore reserves the right to make any modifications at any time to elements, details, or accessory supply, as considered necessary for reasons of improvement or manufacturing/commercial requirements.
The reproduction, even partial, of the text and drawings contained in this document is prohibited by law.

The company reserves the right to make any technical and/or supply modifications. The images are for reference purposes only, and are not binding in terms of design and supply.

Symbols used in the manual



Open book symbol with an "i"
Indicates the need to consult the instruction manual

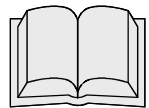

Open book symbol
Used to tell the operator to read the manual before using the machine



Warning symbol
Carefully read the sections marked with this symbol and observe the indications, for the safety of the operator and the machine



Warning symbol
Indicates danger of gas exhalation and leakage of corrosive liquids



Warning symbol
Indicates operator should take safety measures to avoid damage to limbs.



Warning symbol
Indicates the danger of fire.
Do not go near with free flames



Warning symbol
Indicates that the packed product should be handled with suitable lifting means that comply with the legal requirements



Disposal symbol
Carefully read the sections marked with this symbol for the disposal of the machine



CONTENTS

ON CONSIGNMENT OF THE MACHINE	5
SERIAL NUMBER PLATE.....	5
INTRODUCTORY COMMENT	5
INTENDED USE	5
TECHNICAL DESCRIPTION.....	6
SYMBOLS USED ON THE MACHINE.....	7
GENERAL SAFETY REGULATIONS.....	10
MACHINE PREPARATION.....	11
1. HANDLING OF THE PACKED MACHINE	11
2. HOW TO MOVE THE MACHINE	11
3. INSTRUMENT PANEL COMPONENTS	11
4. STEERING COLUMN COMPONENTS	12
5. FOOTBOARD COMPONENTS	13
6. SEAT SUPPORT COMPONENTS	13
7. REAR COMPONENTS OF THE MACHINE	13
8. FRONT MACHINE COMPONENTS.....	14
9. BATTERY TYPE.....	14
10. BATTERY MAINTENANCE AND DISPOSAL.....	14
11. HANDLING - INSERTING BATTERIES	14
12. BATTERY CONNECTION AND BATTERY CONNECTORS.....	15
13. CONNECTING THE BATTERY CHARGER.....	16
14. BATTERY CHARGE LEVEL INDICATOR (BATTERY VERSION).....	16
15. SERVICE BRAKE – PARKING BRAKE	17
16. WORKING FORWARD SPEED.....	17
17. SIDE BRUSHES.....	17
18. INCREASING THE PRESSURE ON THE BRUSH HEAD UNIT	18
19. SOLUTION TANK	18
20. FILLING THE SOLUTION TANK.....	18
21. REGULATING THE DETERGENT	18
22. RECOVERY TANK.....	19
23. SQUEEGEE ASSEMBLY.....	19
24. ADJUSTINGTHE SQUEEGEE INCLINATION.....	19
25. ADJUSTINGTHE SQUEEGEE HEIGHT	19
26. CYLINDRICAL BRUSH ASSEMBLY	20
27. SIDE BRUSH ASSEMBLY	21
WORK.....	22
28. WORK.....	22
29. BRAKING SYSTEM OIL LEVEL	23
30. CHOPPER CIRCUIT BOARD FAULT	23
31. SOLUTION TANK EMPTY	23
32. BRUSH HEAD MOTOR UNDER PRESSURE.....	23
33. SIDE BRUSH HANDLING	23
AT THE END OF THE WORK	24
34. •AT THE END OF WORK	24
DAILY MAINTENANCE	26
35. CLEANING THE VACUUM MOTOR FILTER.....	26
36. CLEANING THE RECOVERY TANK	27
37. CLEANING THE SQUEEGEE.....	28
38. CLEANING THE SOLUTION TANK FILTER.....	28
39. CLEANING DEBRIS HOPPER AND HOPPER VACUUM FILTER	29
WEEKLY MAINTENANCE.....	30
40. CLEANING THE VACUUM HOSE	30
41. CLEANING THE SOLUTION TANK.....	31
42. CYLINDRICAL BRUSH CLEANING.....	31



43. CLEANING THE SIDE BRUSH	32
EXTRAORDINARY MAINTENANCE	33
44. REPLACING THE FRONT SQUEEGEE RUBBER	33
45. REPLACING THE REAR SQUEEGEE RUBBER	33
46. REPLACEMENT OF THE BRUSH HEAD SIDE SPLASH GUARD RUBBER	33
47. SIDE SPLASH GUARD HEIGHT ADJUSTMENT	34
48. CLEANING THE DETERGENT SOLUTION SUPPLY PIPE	34
TROUBLESHOOTING	36
49. THE MACHINE DOES NOT START	36
50. INSUFFICIENT WATER ON THE BRUSHES	36
51. THE SQUEEGEE DOES NOT DRY PERFECTLY	36
52. THE MACHINE DOES NOT CLEAN WELL	36
53. EXCESSIVE FOAM PRODUCTION	36
54. THE VACUUM CLEANER DOES NOT FUNCTION	36
55. THE BRUSH MOTOR DOES NOT WORK	36
56. ELECTRIC FUSES AND THERMAL CUT-OUTS	37
57. THE AUTOMATIC WATER/DETERGENT DOSING SYSTEM DOES NOT WORK	37
58. ALARMS	37
DISPOSAL	38
CHOOSING AND USING THE BRUSHES	39
EC DECLARATION OF CONFORMITY	40



On consignment of the machine

When the machine is delivered to the customer, an immediate check must be performed to ensure all the material mentioned in the shipping documents has been received, in addition to verifying that the machine has not been damaged during transportation. If this is the case, the carrier must ascertain the extent of the damage at once, informing our customer service office. It is only by prompt action of this type that the missing material can be obtained, and compensation for damage successfully claimed.

Introductory comment

SMG is a floor scrubbing machine which, by means of the mechanical action of the rotating brush and the chemical action of a water/detergent solution, can clean any type of flooring. As it advances, it also collects any removed dirt as well as the detergent solution not absorbed by the floor.

The machine must only be used for this purpose. Even the best machines will only work well if used correctly and kept in good working order. We therefore suggest you read this instruction booklet carefully and read it again whenever difficulties arise while using the machine. If necessary, remember that our customer assistance service (organised in collaboration with our dealers) is always available for advice or direct intervention.

Intended use

The scrubbing machine is exclusively designed for the professional cleaning of surfaces and floors in industrial, commercial and public environments. The machine is only suitable for use in closed - or at least covered - places.

The machine is not suitable for use in the rain, or under water jets. It is **FORBIDDEN** to use the machine for picking up dangerous dusts or inflammable liquids within places with a potentially explosive atmosphere. In addition, it is not suitable as a means of transport for people or objects.

Serial number plate

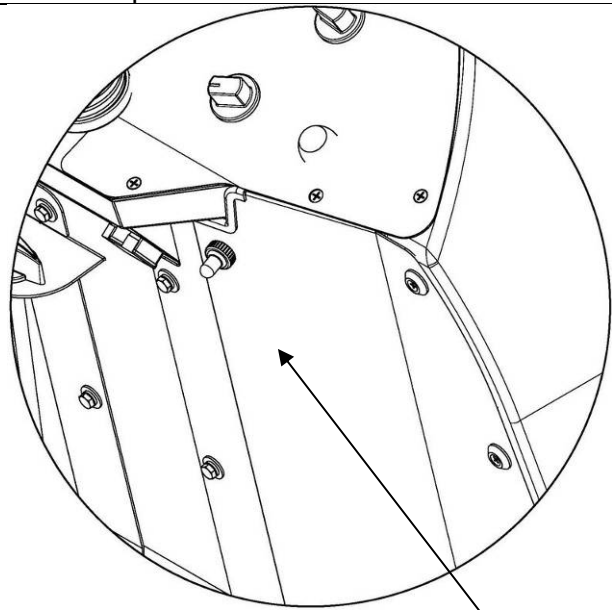



TECHNICAL DESCRIPTION	UM	SMG130 S BASIC
Working width (without side brushes)	mm	1055
Working width (with side brushes)	mm	1370
Squeegee width	mm	1266
Working capacity, up to	m ² /h	9320
Cylindrical brush	No. / Ø mm	2 / 210
Cylindrical brush rotations	rpm	650
Cylindrical brush motor	No. / V / W	36 / 1300
Maximum pressure on the brushes	kg	80
Side disc brush	No. / Ø mm	2 / 450
Side disc brush rotations	rpm	84
Side brush motor	V/W	24 / 90
Traction motor	V/W	24 / 1500
Traction wheel (diameter / width)	Ø mm / mm	300 / 120
Maximum forward speed	km/h	6.8
Maximum gradient with full load	%	10
Vacuum motor	No./(V/W)	2 / (36 / 650)
Suction vacuum	mbar	1405
Rear elastic wheels (diameter / width)	Ø mm / mm	370 / 140
Solution tank	l	283
Recovery tank	l	335
Steering diameter	mm	2900
Machine length	mm	2160
Machine height	mm	1676
Machine width (without squeegee)	mm	1340
Battery compartment (l x L x h)	mm	740x540x525
Rated battery voltage	V/Ah	36 / 360
Battery weight (max)	kg	480
Machine weight (empty and without batteries)	kg	687
Gross weight in running order (machine + batteries + water + operator)	kg	1536
Sound pressure level (ISO 11201)	dB (A)	-
Hand vibration level (ISO 5349-1)	m/s ²	-
Body vibration level	m/s ²	-



SYMBOLS USED ON THE MACHINE

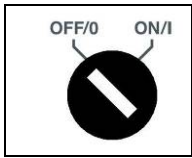

Main switch or key switch symbol
Used on the instrument panel, to indicate the key switch for machine operation on (ON-1) or off (OFF-0)



Symbol denoting acoustic alarm
Used to indicate the acoustic alarm button

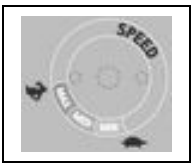

Symbol denoting forwards and backwards speed selector
Used on the instrument panel, to indicate the speed of the forwards or backwards movements of the machine

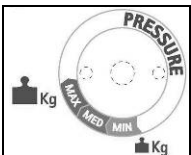

Symbol denoting pressure applied to the brushes
Used to indicate the knob for increasing the brush pressure

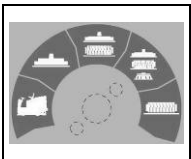

Brush head / squeegee operating symbols
Used to indicate the I-DRIVE programs selector



Symbol denoting incorrect functioning
Used on the instrument panel to indicate the red warning light showing incorrect machine traction functioning



Symbol denoting ammetric check of the brush motor
Used on the instrument panel, for the red indicator light showing the brush motor is under pressure (force)



Symbol denoting parking brake engaged or incorrect braking system fluid level
Used on the instrument panel to indicate the red warning light showing the engagement of parking brake or the absence of oil in the work braking system



Symbol denoting solution tank empty
Used on the instrument panel to indicate the red warning light showing a low level of water/detergent solution in the solution tank



SYMBOLS USED ON THE MACHINE



Symbol denoting recovery tank rotation
Used on the instrument panel, for the green indicator light indicating rotation consent to recovery tank



Symbol denoting tap regulation
Used on the central panel of the steering cover, to indicate the tap knob to regulate the water

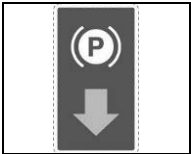

Parking brake pedal symbol
Used on the solution tank to indicate the position of the parking brake pedal



Symbol denoting the machine's power supply voltage
Used on the front of the machine, in correspondence with the battery charger socket insertion nozzle, to indicate the machine's power supply voltage



Label warning operator to take safety measures to avoid damage to limbs



Label indicating the position of the quick release coupling for filling the solution tank



Symbol indicating the maximum temperature of the water used to fill the solution tank



Symbol indicating the position of the solution tank drain pipe



Symbol indicating the position of the recovery tank drain pipe

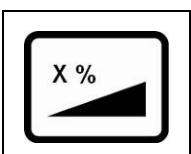

Indicates the maximum gradient



SYMBOLS USED ON THE MACHINE



Label relating to uncoupling the seat support
Displayed on the seat support to indicate the uncoupling handle



Symbol denoting treading ban
Used to indicate the area of the machine on which it is forbidden to tread or stand

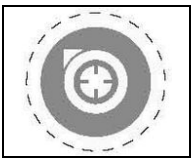

Label indicating the position of the vacuum motor thermal circuit breakers



GENERAL SAFETY REGULATIONS

The regulations below must be carefully followed in order to avoid harm to the operator and damage to the machine.

WARNING:

- Read the labels on the machine carefully. Do not cover them for any reason and replace them immediately if they become damaged.
- The machine must be used exclusively by authorised and trained personnel.
- Do not use the machine on surfaces with an inclination greater than the one shown on the plate.
- The machine is not suitable for cleaning rough or uneven floors. Do not use the machine on slopes.
- If the power supply cable of the battery charger is damaged, contact an Authorised service centre immediately.
- In the event of danger, quickly press the emergency button on the control panel.
- For all maintenance interventions, switch off the machine and disconnect the battery connector and/or the power supply cable.
- Children must be supervised to ensure they do not play with the device.
- During the working of the machine, pay attention to other people and especially to children.
- Only use the brushes supplied with the machine, or those specified in the "CHOOSING AND USING THE BRUSHES" paragraph of the instruction manual. The use of other brushes could compromise safety levels.

WARNING:

- The machine is not suitable for use by children and persons with reduced physical, mental and sensory capabilities, or people who lack experience and knowledge.
- The machine must not be used or stored outdoors, in damp conditions or directly exposed to rain.
- The storage temperature must be between -25°C and +55°C; do not store outdoors in damp conditions.
- Conditions of use: room temperature between 0°C and 40°C with relative humidity between 30 and 95%.
- The socket for the machine's power cable (electric version) or for the battery charger power cable (battery version) must be correctly earthed.
- Adapt the speed to the adhesion conditions.
- Do not use the machine as a means of transport.
- The machine does not cause harmful vibrations.
- Do not use the machine in an explosive atmosphere.
- Do not vacuum inflammable liquids.
- Do not use the device to collect dangerous powders.
- Do not mix different types of detergent as this may produce harmful gases.
- The machine is not suitable for cleaning carpets.
- Do not place any liquid containers on the machine.
- Avoid working with the brushes when the machine is standing still, so as not to damage the floor.
- In the event of a fire, use a powder extinguisher. Do not use water.
- Do not knock against shelving or scaffolding, where there is a danger of falling objects. The operator must always be equipped with the appropriate safety devices (gloves, shoes, helmet, goggles, etc.).
- The machine is designed to carry out the scrubbing and drying operations simultaneously. Different operations should only be carried out in areas where the passage of unauthorised persons is prohibited. Signal the presence of damp floors with suitable signs.
- If the machine does not work properly, check this is not caused by failure to carry out routine maintenance. Otherwise, ask for intervention of the authorised technical assistance centre.
- If you need to replace any components, request the ORIGINAL spare parts from an Authorised dealer and/or Retailer.
- Restore all electrical connections after any maintenance interventions.
- Before using the machine, check that all the hatches and covers are positioned as shown in this Use and Maintenance Manual.
- Do not remove the guards that can only be removed with the aid of tools, except for maintenance work (see the relevant paragraphs)
- Do not wash the machine with direct water jets or with pressurised water, nor with corrosive substances.
- To prevent scaling in the solution tank filter, do not fill the tank with detergent solution many hours before using the machine.
- Do not use acid or basic solutions that could damage the machine and/or harm people.
- Have the machine checked by an authorised technical assistance centre every year.
- When disposing of consumable materials, observe the laws and regulations in force.
- When your machine has reached the end of its long working life, dispose of the materials it contains (especially oils, batteries and electronic components) in an appropriate manner, taking into account that the machine itself was constructed using 100% recyclable materials.
- The batteries must be removed from the machine before its disposal. The batteries must be disposed of in a safe manner, fully observing the laws and regulations in force.



MACHINE PREPARATION

1. HANDLING OF THE PACKED MACHINE

The machine is contained in specific packaging with a pallet for the handling with fork trucks. The packages cannot be placed on top of each other.

The total weight of the machine and packaging is 780kg

The dimensions of the packaging is as follows:

SMG130 S

A: 1620mm

B: 1520 mm

C: 2380 mm

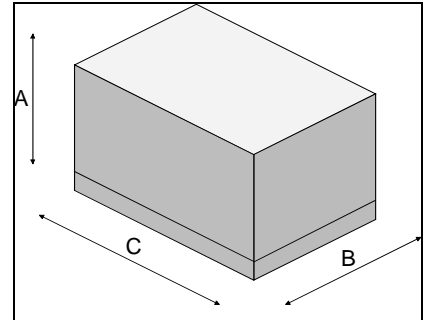

1. Remove the outer packaging
2. The machine is fixed to the pallet with wedges which block the wheels
3. Remove the wedges
4. Use a chute to get the machine down from the pallet, pushing it backwards. Do not assemble the rear squeegee before unloading the machine, and avoid violently jolting the brush head. To assemble the squeegee, read the "SQUEEGEE ASSEMBLY" paragraph.

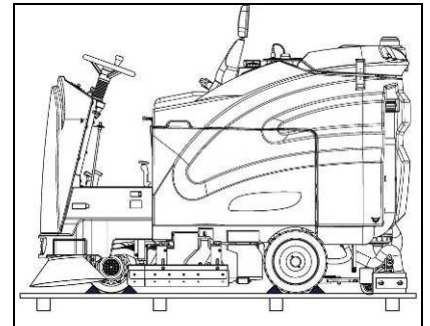

5. Keep the pallet for any future transport needs



WARNING: If the product is delivered in cardboard containers, handle the packed product with suitable lifting means that comply with the legal requirements



WARNING: During this operation, check there are no people or objects near the machine

2. HOW TO MOVE THE MACHINE

1. Make sure the solution tank and the recovery tank are empty
2. Check that the detergent canister is empty
3. Check that the brush head and squeegee are in the raised position
4. Place it on a pallet using a chute
5. Check that the key switch is in the "0" position and remove the key
6. Engage the parking brake
7. Secure the machine to the pallet using wooden wedges

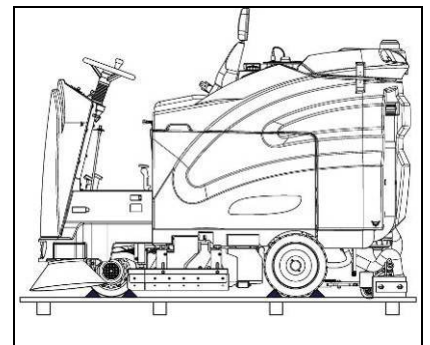

3. INSTRUMENT PANEL COMPONENTS

The instrument panel components are identified as follows:

1. 3-way switch to set working speed
2. Main key switch

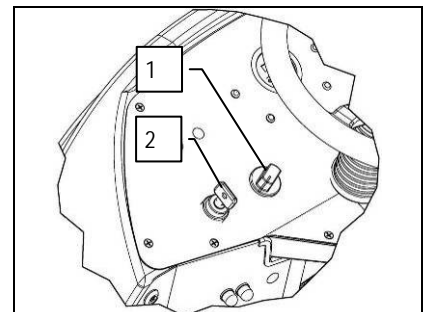



MACHINE PREPARATION

- 3. Level indicator for battery/hour meter
- 4. Red warning light indicating that there is a malfunction in the machine traction
- 5. Red indicator light, indicates that the parking brake is engaged or indicates the machine's braking system oil reserve level

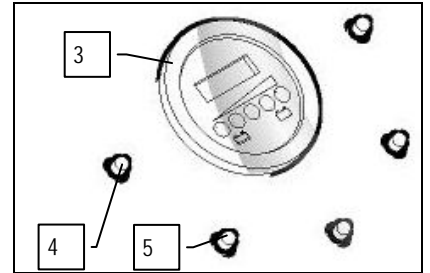

- 6. Red warning light indicating that the motor brush head is working under pressure (force)
- 7. Red indicator light, indicates that the water has reached reserve level
- 8. Green indicator light, indicates consent to rotate the recovery tank

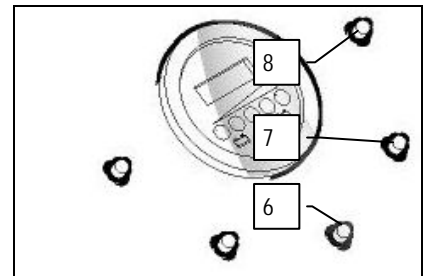

- 9. 3-way switch to set force applied to brushes during operation
- 10. Horn button
- 11. Working program adjustment switch, I-Drive device

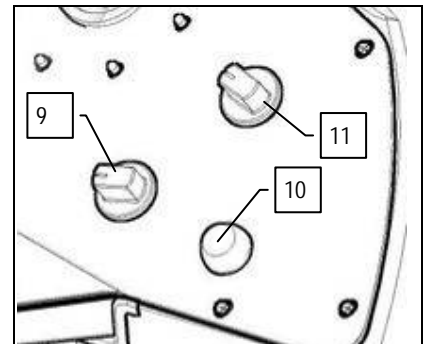

Choose the desired operating program with the I-Drive device:

- A. Transfer: movement of the machine without working
- B. Drying: use the squeegee only
- C. Central brushes Scrubbing / Drying: use both the brushes and the squeegee
- D. Central brushes Scrubbing / Drying / Side brushes: use both the brushes and the squeegee, with the addition of the side brushes to gather the dirt
- E. Scrubbing only: use brushes only

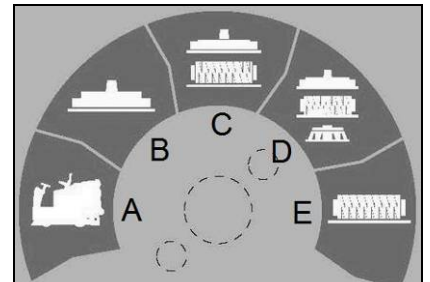

4. STEERING COLUMN COMPONENTS

The steering column components on the left side are identified as follows:

- 12. Vacuum motor thermal circuit breakers
- 13. Water adjustment knob

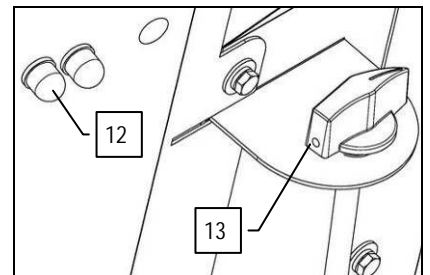



MACHINE PREPARATION

5. FOOTBOARD COMPONENTS

The components at the front right of the footboard are identified as follows:

- 14. Forward movement pedal
- 15. Backward movement pedal
- 16. Brake pedal

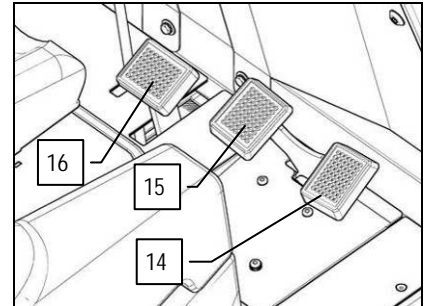

- 17. Parking brake pedal
- 18. Battery charger plug insertion hatch

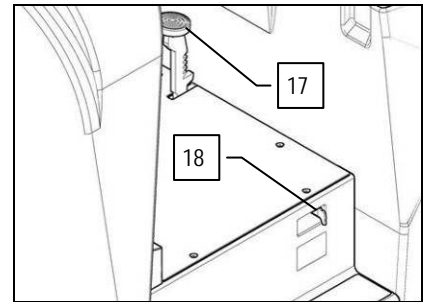

6. SEAT SUPPORT COMPONENTS

The seat support components are identified as follows:

- 19. Seat lifting handle
- 20. Safety belt (optional)

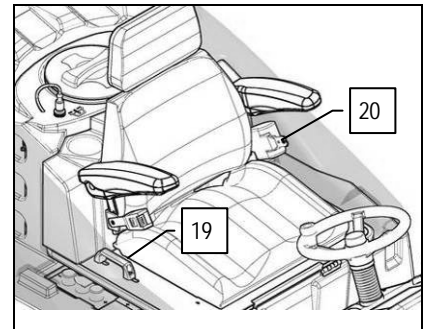

7. REAR COMPONENTS OF THE MACHINE

The rear components of the machine are identified as follows:

- 21. Solution tank drain pipe

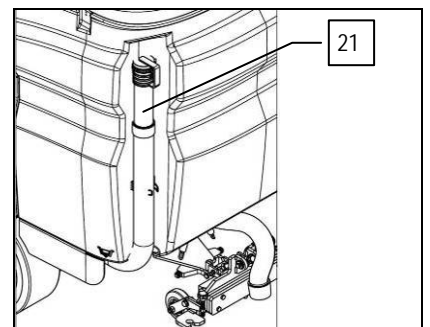

- 22. Recovery tank drain pipe
- 23. Recovery tank discharge cap

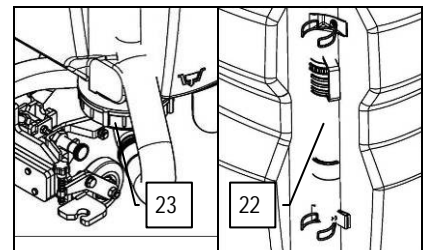



MACHINE PREPARATION

- 24. Flashing warning light
- 25. Water/detergent solution filler cap
- 26. Rapid refill kit (optional)

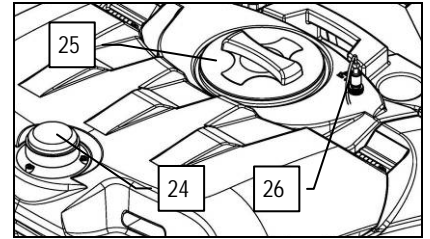

8. FRONT MACHINE COMPONENTS

The front components of the machine are identified as follows:

- 27. Headlights (optional)

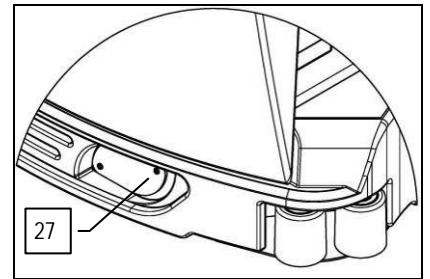

9. BATTERY TYPE

To power the machine it is necessary to use:

- liquidelectrolyte lead traction batteries;
- sealed traction batteries with gas recombination or gel technology.

OTHER TYPES MUST NOT BE USED.

The batteries must meet the requirements laid out in the norms: CEI EN 60254-1:2005-12 (CEI 21-5) + CEI EN 60254-2:2008-06 (CEI 21-7)

For a good operating performance, we suggest the use of two 18V 360 Ah/C5 battery cases

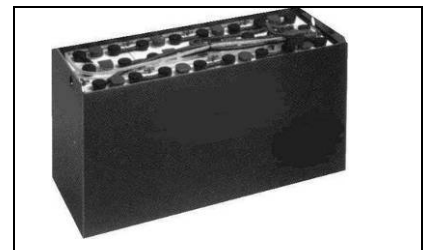

10. BATTERY MAINTENANCE AND DISPOSAL

For maintenance and recharging, respect the instructions provided by the battery manufacturer.

Particular attention must be paid when choosing the battery charger, if not supplied, since there are different kinds according to the type and capacity of the battery.

When the battery reaches the end of its working life, it must be disconnected by expert, trained personnel then removed from the battery compartment with the aid of suitable lifting devices. EXHAUSTED BATTERIES ARE CLASSIFIED AS DANGEROUS WASTE AND MUST BE CONSIGNED TO THE AUTHORISED BODIES FOR CORRECT DISPOSAL.



WARNING: You are advised to always wear protective gloves, to avoid the risk of serious injury to your hands.



WARNING: You are advised to only lift and move the batteries with lifting and transportation means suitable for the specific weight and size

11. HANDLING - INSERTING BATTERIES

The batteries must be housed in the special compartment beneath the seat casing. They should be handled using lifting equipment that is suitable in terms of both weight and coupling system. They must also satisfy the requirements of Standard CEI 21-5. The dimensions of the battery compartment are: 740mm x 540mm x H525mm.



WARNING: For battery maintenance and daily recharging, you must carefully follow the instructions provided by the manufacturer or retailer. All installation and maintenance operations must be carried out by specialised personnel.



MACHINE PREPARATION



WARNING: you are advised to use airtight batteries only, to avoid the leakage of acids!



WARNING: you are advised to always wear protective gloves, to avoid the risk of serious injury to your hands.

To insert batteries proceed as follows:

1. Lock the machine using the parking brake, by pressing down on the pedal (1) and moving it towards the rear of the machine
2. Make sure the recovery tank is empty, otherwise empty it completely
3. Make sure the detergent tank is empty, otherwise empty it completely
4. Check that the main switch is in the "Off -0" position
5. Grip the seat rotation uncoupling handle (2), move it forward as far as it will go
6. Rotate the seat support as far as it will go, this will enable access to the battery compartment

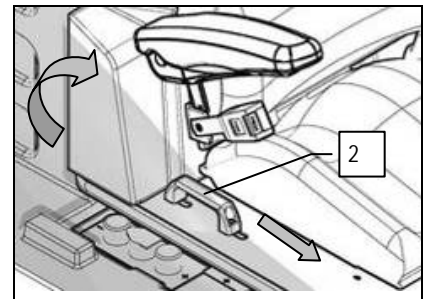
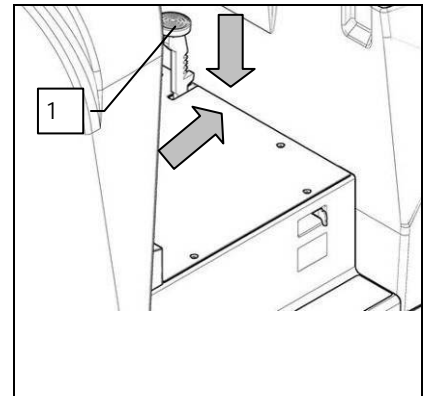

ATTENTION: You are advised to only lift and move the batteries with lifting and transportation means suitable for the specific weight and size

7. Grip the handle (3) moulded into the recovery tank
8. Rotate the recovery tank seat as far as it will go

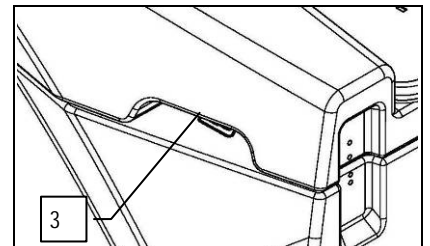

ATTENTION: You are advised to only lift and move the batteries with lifting and transportation means suitable for the specific weight and size

9. Using suitable equipment disconnect the gas springs (6) from their support (7)
10. Place the batteries inside the battery compartment using transport and handling equipment suitable for the weight and size of the batteries
11. Place the batteries in the battery compartment with the "+" and "-" poles opposite each other

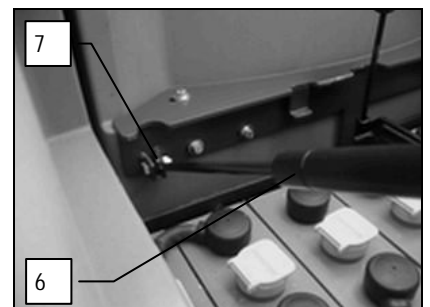

12. BATTERY CONNECTION AND BATTERY CONNECTORS

1. Connect the batteries in series to the "+" and "-" poles using the supplied jumper cable
2. Connect the battery connector cable to the "+" and "-" poles in order to obtain a voltage of 36V at the connection terminals
3. Connect the battery connector cable to the machine connector (6)
4. Using suitable equipment, attach the gas springs (4) to their support (5)
5. Grip the handle (3) moulded into the recovery tank and rotate it to the work position
6. Rotate the seat support until it is in the working position



WARNING: All installation and maintenance operations must be carried out by expert personnel, trained at the specialised assistance centre

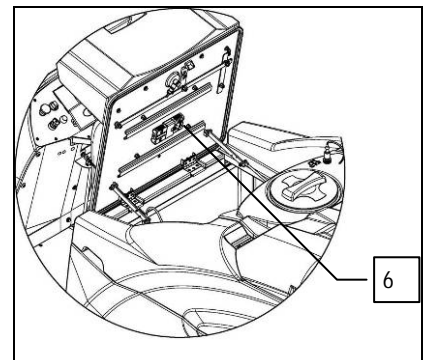



MACHINE PREPARATION

13. CONNECTING THE BATTERY CHARGER

In order not to cause permanent damage to the batteries, it is essential to avoid their complete discharge: arrange the recharge within a few minutes of the switching on of the "discharged batteries" blinking light.



WARNING: Never leave the batteries completely discharged, even if the machine is not being used. Check the battery charger is suitable for the batteries installed, in terms of both capacity and type.

To connect the battery charger you must:

1. Move the machine near to the battery charger
2. Make sure that the key switch in the "0" position
3. Engage the parking brake
4. Grip the seat rotation uncoupling handle (1), move it forward as far as it will go
5. Rotate the seat support as far as it will go

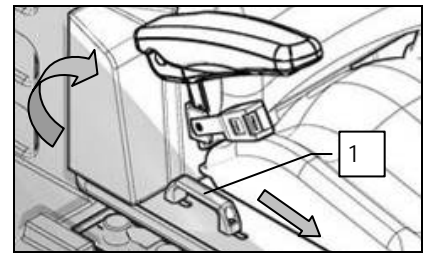

The coupling connector of the battery charger is supplied inside the bag containing this instruction booklet, and must be fitted to the battery charger cables as shown in the instructions.



WARNING: This process must be carried out by qualified personnel. An incorrect connection of the connector may cause problems with machine functioning.

6. Open the hatch (2) and connect the recently wired cable to the external battery charger
7. When the recharge cycle is complete, disconnect the battery charger cable from the machine

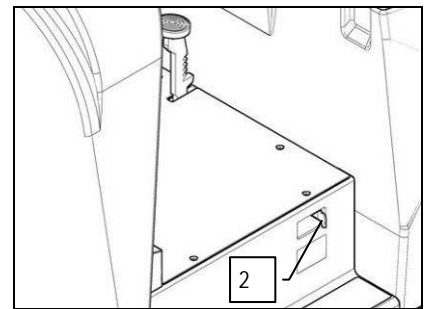

WARNING: Carefully read the use and maintenance instructions of the battery charger that is used for charging.

WARNING: Keep the seat support lifted for the duration of the battery recharging cycle to allow gas fumes to escape



WARNING: Danger of gas exhalation and leakage of corrosive liquids.



WARNING: Danger of fire: do not go near with free flames

14. BATTERY CHARGE LEVEL INDICATOR (BATTERY VERSION)

The battery indicator uses LEDs and has 8 positions (7 yellow - charged batteries, and 1 red - run down batteries).



WARNING: A few seconds after the red indicator light comes on, the brush motor switches off automatically. With the remaining charge it is possible to complete the drying process before recharging

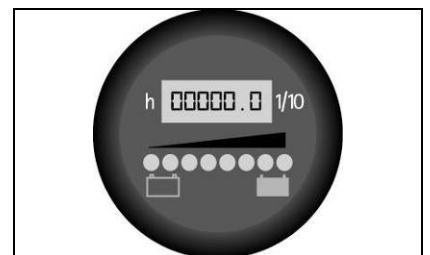



MACHINE PREPARATION

15. SERVICE BRAKE – PARKING BRAKE

The machine has an electronic braking system. To brake, in normal conditions, just remove your foot from the accelerator pedal. If this service brake is working badly, or if necessary, activate the brake pedal (1) pushing it downwards.

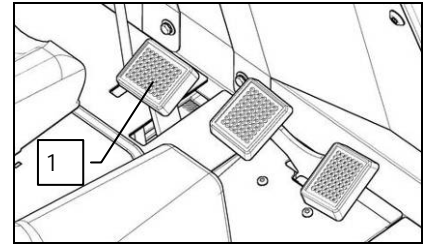

In case of lack of oil in the braking system, the red warning light (2) on the instrument panel will come on; contact the technician to check the level of brake oil.

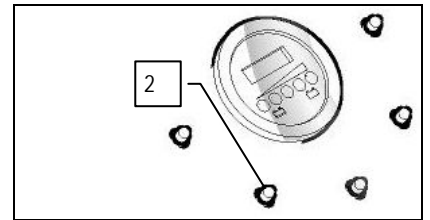

Press downwards on the pedal (3) and pull it towards the rear of the machine to engage the parking brake.

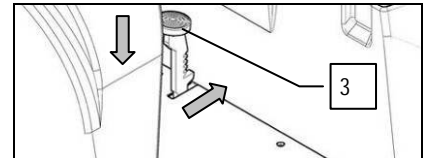

16. WORKING FORWARD SPEED

This machine is equipped with electronic traction control. To move the machine, turn the key to "ON - I" then press the forward drive pedal (1), adjusting the speed by altering the degree of pressure on the pedal.

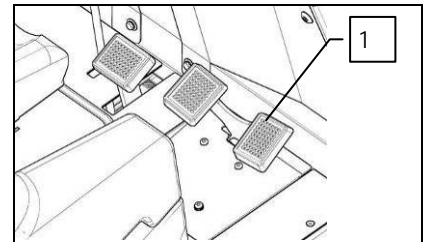

The machine has three preset speed levels, to select them simply operate the switch (2) on the instrument panel; the forward speed during operation depends on the amount of dirt to be removed and the type of floor to be cleaned.

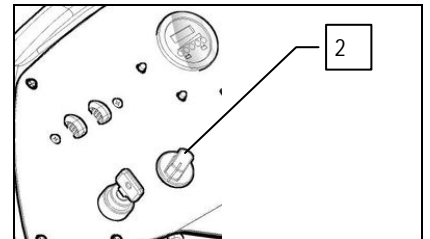

- Step01: the maximum speed is 3 km/h
- Step02: the maximum speed is 4.8 km/h
- Step03: the maximum speed is 6.8 km/h

To move the machine in reverse, simply depress the pedal (3); the machine speed is controlled by varying the pressure on the pedal.

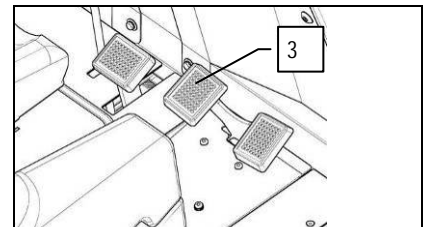

WARNING! The reverse speed is lower than the forward speed to comply with current health and safety standards.

17. SIDE BRUSHES

This machine offers the option of using two side brushes to transport the dirt towards the centre of the machine. To do this, rotate the i-drive selector to the "D" position. To resume using the cylindrical brushes only, rotate the i-drive selector to the "C" position.

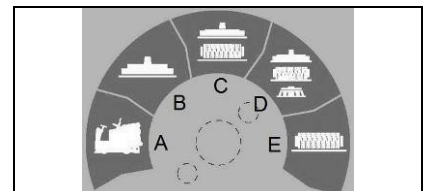



MACHINE PREPARATION

18. INCREASING THE PRESSURE ON THE BRUSH HEAD UNIT

This machine can increase the pressure on the brushes via the knob (1) located on the instrument panel; it has three different settings:

- Step01: the weight exerted on the floor is 53 kg.
- Step02: the weight exerted on the floor is 65 kg.
- Step03: the weight exerted on the floor is 80 kg.



ATTENTION! The pressure must be chosen according to the type of floor and the amount of dirt. Increasing the pressure results in greater wear and tear on the brushes and higher power consumption (for further information, read "CHOOSING AND USING THE BRUSHES")

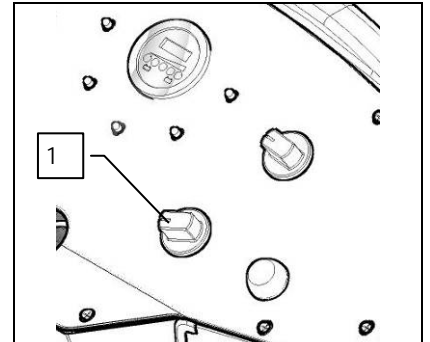

19. SOLUTION TANK

Remove the filler plug (1) at the back of the seat and check that the solution filter is installed properly. Check that the drainage hose cap (2) located at the rear of the machine is properly closed.



WARNING: The recovery tank must be completely empty each time the solution tank is filled.

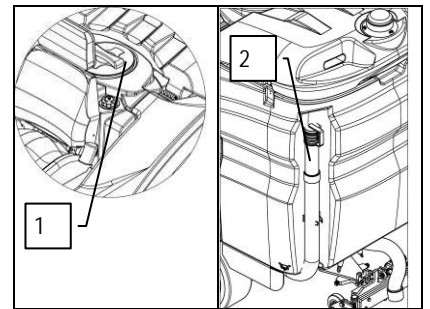

20. FILLING THE SOLUTION TANK

Proceed as follows to fill the solution tank:

1. Turn the main switch key anticlockwise to the "0" position
2. Engage the parking brake
3. Remove the filler cap (1) and check that the solution filter is fitted correctly
4. Fill it with clean water at a temperature not exceeding 50°C.

It is possible to fill the tank without having to constantly watch the water level, using the optional rapid filling system (2); this system is fitted with a float to control overflow. The water pipe (previously modified) is inserted into the quick release coupling; remember to unscrew the cap (1) to allow proper air venting.

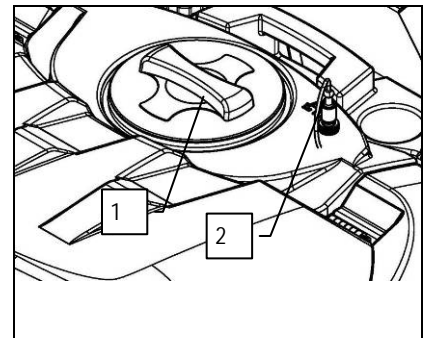

WARNING: Always use detergents whose manufacturer's label indicates their suitability for scrubbing machines. Do not use acid or alkaline products or solvents without this indication.

In addition, you are advised to always use low foam detergents

Do not use pure acids or detergents with a stronger gradation than that indicated on the label supplied.



ATTENTION: Protective gloves should always be worn before handling detergents or acidic or alkaline solutions to avoid serious injury to hands.

21. REGULATING THE DETERGENT

Firstly, fully open the outflow of the tap, by means of the lever (1) on the steering column. During the first few metres, check that the amount of solution is sufficient to wet the floor, the amount of detergent can be adjusted by means of the lever (1) (rotating it anticlockwise to increase the flow, or in the opposite direction to reduce it). Bear in mind that the correct amount of solution is always depends on the nature of the floor, the degree of dirt and the forward speed.

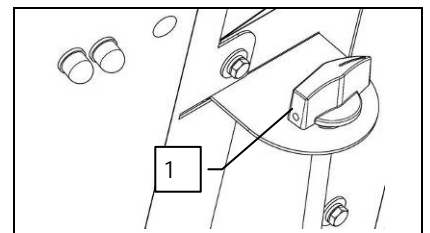



MACHINE PREPARATION

22. RECOVERY TANK

Make sure the recovery tank is empty, otherwise empty it completely.
Check the cap of the drainage hose (1) (on the rear of the machine) is correctly closed.
Check that the drain pipe cap (2) at the rear of the machine is correctly closed.

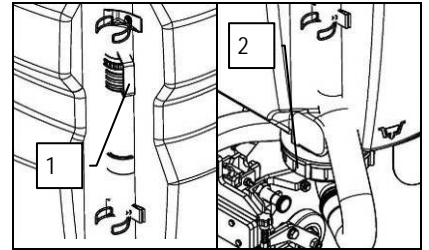

23. SQUEEGEE ASSEMBLY

The squeegee, that for reasons of packaging comes disassembled from the machine, must be assembled while assembling the machine. Proceed as follows for assembly:

1. Check that the squeegee support is raised
 2. Turn the main switch key anticlockwise to the "0" position
 3. Engage the parking brake
 4. Remove the key from the instrument panel
-
5. First insert the left-hand pin of the squeegee into the left-hand slot of the squeegee connection and screw the stud (1) on to the pin, making sure that it fits tightly into its seat on the squeegee support
 6. Insert the right-hand pin of the squeegee into the right-hand slot of the squeegee connection and screw the stud (2) on to the pin, making sure that it fits tightly into its seat on the squeegee support
 7. Insert the vacuum hose into the squeegee sleeve

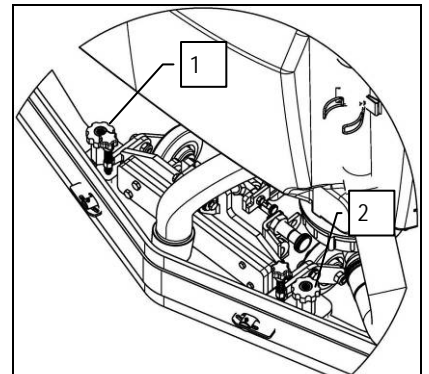
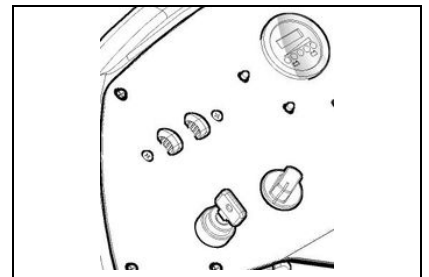

ATTENTION: these operations must be carried out using protective gloves to avoid any possible contact with the edges or tips of metal objects.

24. ADJUSTING THE SQUEEGEE INCLINATION

During working operation, the rear rubber is slightly tilted backwards (by about 5mm) in a uniform way for its whole length. If you need to increase the bend of the rubber in the central part, you must tilt the squeegee unit. To do this, proceed as follows:

1. Loosen the locknut (1)
2. Turn the screw (2) in an anti-clockwise direction to increase the bend of the rubber in the central part of the squeegee. To increase the bend of the rubber at the sides of the squeegee, rotate the screw (2) clockwise.
3. When fully adjusted, fix the locknut (1)

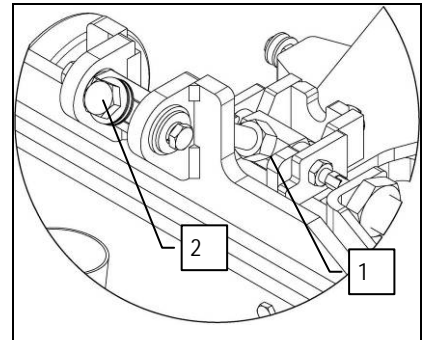

25. ADJUSTING THE SQUEEGEE HEIGHT

The height of the squeegee must be adjusted on the basis of the state of wear and tear of the rubber. To do this, turn the knob (1) anticlockwise to raise the squeegee, and clockwise to lower it.

Remarks: the right and left wheels must be adjusted to the same level, so the squeegee can work parallel to the floor.



ATTENTION: these operations must be carried out using protective gloves to avoid any possible contact with the edges or tips of metal objects.

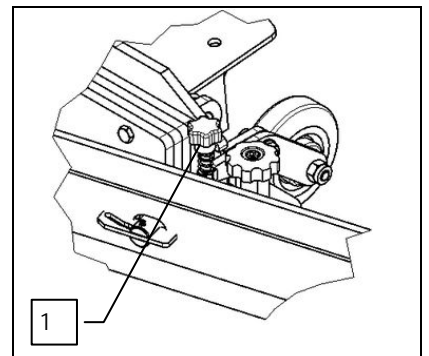



MACHINE PREPARATION

26. CYLINDRICAL BRUSH ASSEMBLY

To assemble the cylindrical brushes of the brush head unit, proceed as follows:

1. Turn the key of the main switch (1) a quarter of a turn clockwise (to position 1).
2. Lift the brush head unit by operating the knob, the selected working program must be "Transport" (position A)
3. Turn the main switch key (1) anticlockwise by a quarter of a turn (to position 0).

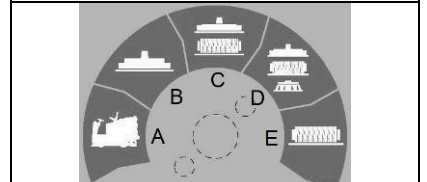
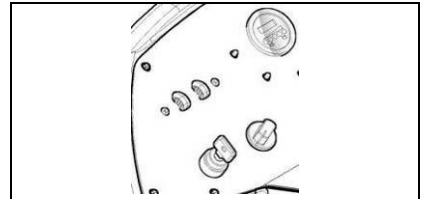

4. Engage the parking brake
5. Grip the seat rotation uncoupling handle (1), move it forward as far as it will go
6. Rotate the seat support as far as it will go
7. Disconnect the battery connector cable from the machine connector



WARNING: Before performing any maintenance, remove the keys from the panel and disconnect the battery connector

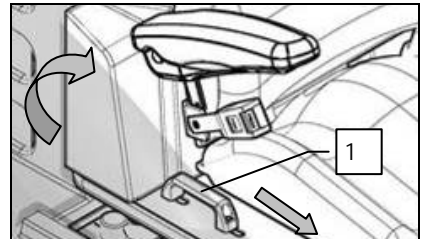

8. Use a suitable tool to remove the splash guard pre-assembly (3), loosening the screws (2) that fix it to the brush head.

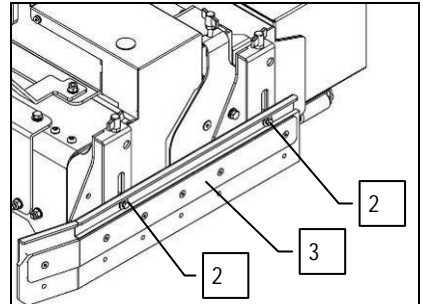

9. Remove the rear brush support (4), unscrew the knob (5) and place it on the ground.

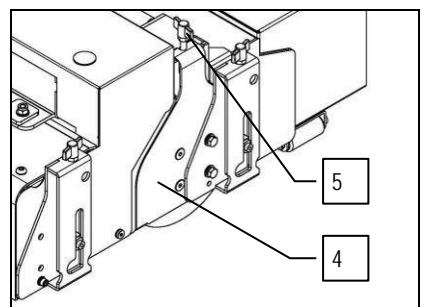

10. Insert the rear brush (5) in the tunnel until it couples with the drive hub on the opposite side of the tunnel



ATTENTION: Pay attention to the direction of the brush bristles during assembly, the cusp of the brush viewed from the above should be towards the rear of the machine.

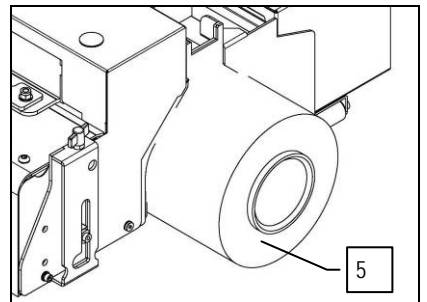



MACHINE PREPARATION



WARNING: Make sure the brushes are correctly connected. If they are not, the machine may not work properly.



WARNING: you are advised to always wear protective gloves, to avoid the risk of serious injury to your hands.

The phases which have been listed here refer to the assembly of the rear brush. Repeat for the front brush.



WARNING: Pay attention to the direction of the brush bristles during assembly, the cusp of the brush viewed from the above should be towards the front of the machine.

27. SIDE BRUSH ASSEMBLY

Proceed as follows to assemble the side brushes:

1. Turn the key of the main switch (1) a quarter of a turn clockwise (to position 1).
2. Lift the brush head unit by operating the knob, the selected working program must be "Transport" (position A)
3. Turn the main switch key (1) anticlockwise by a quarter of a turn (to position 0).

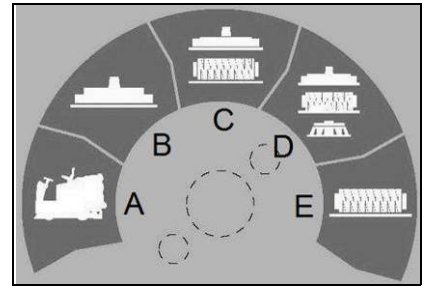

4. Engage the parking brake
5. Grip the seat rotation uncoupling handle (1), move it forward as far as it will go
6. Rotate the seat support as far as it will go
7. Disconnect the battery connector cable from the machine connector

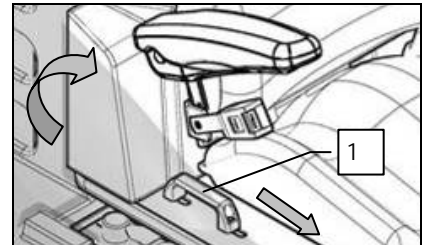

WARNING: Before performing any maintenance, remove the keys from the panel and disconnect the battery connector

8. With the brush-holder arm up, loosen the wing nut (2) and remove the washer (3).
9. Insert the brush in the hub housing, making sure the four pins are inserted in their seats on the brush itself.
10. Insert the washer (3) and tighten the wing nut (2).

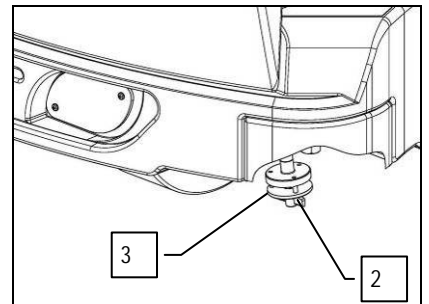

WARNING: You are advised to always wear protective gloves, to avoid the risk of serious injury to your hands.



WORK

28. WORK

Before beginning to work, it is necessary to:

1. make sure the recovery tank is empty, otherwise empty it completely
2. Check that the main switch (3) of the machine is set to "0"
3. connect the battery connector (1) to the electric system connector (2)
4. sit on the driver's seat
5. Check the parking brake is released (4).
6. Turn the key of the main switch a quarter of a turn clockwise (to position 1). Immediately, on the instrument panel, the display will turn on indicating the charge level of the batteries

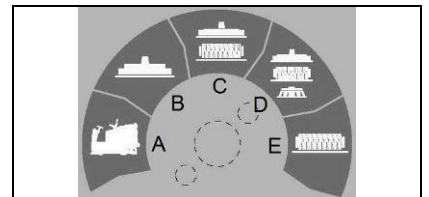
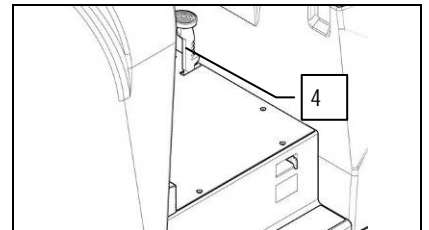
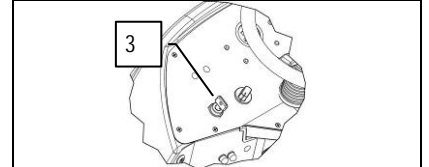
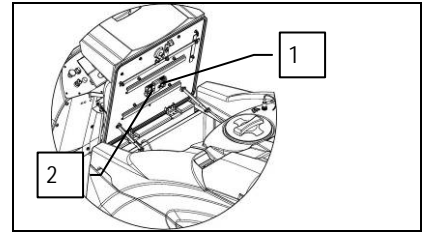

7. Choose the desired working program with the I-Drive device:
 - A. Transfer: movement of the machine without working
 - B. Drying: use the squeegee only
 - C. Scrubbing / Drying: use both the brushes and the squeegee
 - D. Central brushes Scrubbing / Drying / Side brushes: use both the brushes and the squeegee, with the addition of the side brushes to gather the dirt
 - E. Scrubbing only: use brushes only



WARNING! If programs "C - D - E" are selected, the brush head lowers automatically even if the forward movement pedal has not been pushed.

8. Choose the forward operating speed by operating the knob (6) on the instrument panel

This machine can operate at three different speeds: via the knob (5) located on the instrument panel you have three different settings:

- Step01: the maximum speed is 3 km/h
- Step02: the maximum speed is 4.8 km/h
- Step03: the maximum speed is 6.8 km/h

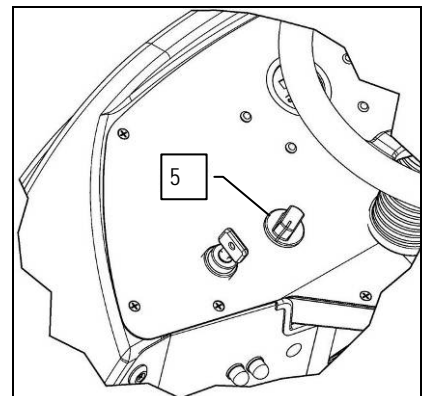

WARNING! The reverse speed is lower than the forward speed to comply with current health and safety standards.

9. Choose the pressure exerted on the brushes by operating the knob (6) on the instrument panel

This machine is capable of increasing the pressure on the brushes using the adjustment bar (6), four separate settings are available:

- Step01: the weight exerted on the floor is 53 kg
- Step02: the weight exerted on the floor is 65 kg
- Step03: the weight exerted on the floor is 80 kg

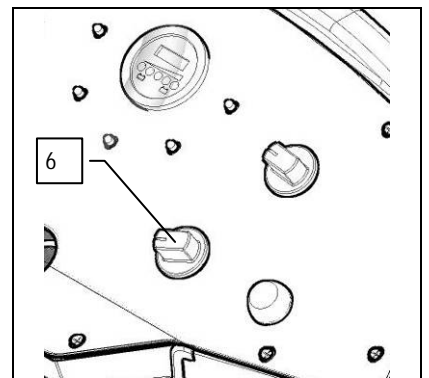

ATTENTION! The pressure must be chosen according to the type of floor and the amount of dirt. Increasing the pressure results in greater wear and tear on the brushes and higher power consumption (for further information, read "CHOOSING AND USING THE BRUSHES")



WORK

10. Rotate the tap lever (7) in an anticlockwise direction, allowing the full passage of the detergent.
11. When the accelerator pedal (8) is pressed, the machine begins to move, the squeegee lowers automatically and the vacuum motors will begin to work. Simultaneously, the brushes will begin to rotate and the solenoid valve will begin to function.

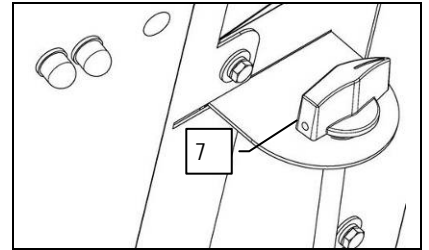

During the first meters, check there is sufficient solution and that the squeegee dries perfectly. The machine will start working in good working order up to run out of detergent solution or until the battery is discharged.

If the drive pedal is released, the flow of detergent will stop, the brush head and squeegee will lift off the ground and the vacuum motors will continue to function for a period of time equal to 25". If the drive pedal is pressed again immediately afterwards, all parameters of the program which was in use prior to the stoppage of the machine are reactivated.

The machine is equipped with two front headlights to allow the operator to work in poorly lit environments. The headlights switch on as soon as the main switch of the machine is in position "1".

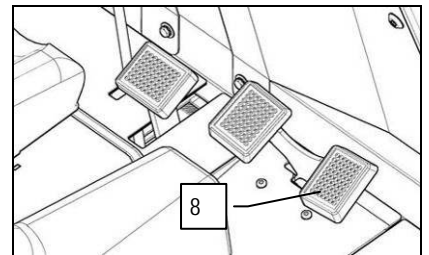

29. BRAKING SYSTEM OIL LEVEL

If the red indicator light (1) comes on while the machine is in use, it means that the level of oil in the machine's braking system has reached a critical stage which may impact upon its correct functioning. Contact a specialised technician immediately.

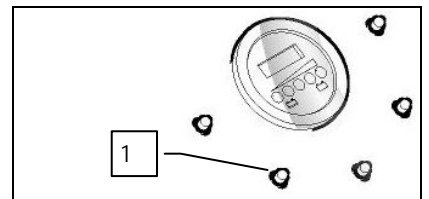

30. CHOPPER CIRCUIT BOARD FAULT

If the red indicator light (2) comes on while the machine is in use, it means that a fault has occurred in the machine's traction control circuit board. Stop the machine immediately and contact a specialised technician.

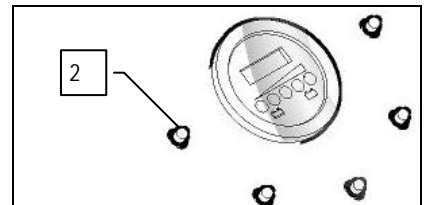

31. SOLUTION TANK EMPTY

If the red indicator light (3) comes on while the machine is in use, it means that the level of solution in the solution tank is too low for the machine to function properly. In this case, raise the squeegee unit and take the machine to the area used for emptying the recovery tank. Then empty the recovery tank using the special drainage hose. Refill the solution tank using the refill opening or the optional rapid refill kit.

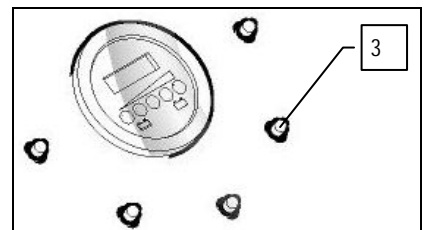

32. BRUSH HEAD MOTOR UNDER PRESSURE

If the red indicator light (4) comes on while the machine is in use, it means that brush motor overload limit level has been exceeded. The motor will come to a stop after a few seconds. To start up the motor again, turn the main switch key off and on again. If the motor stops again, check the reason of the overload in order to prevent damage to the motor. Check to see if the problem persists when the pressure exerted on the brushes is reduced. If it persists, contact a specialised technician.

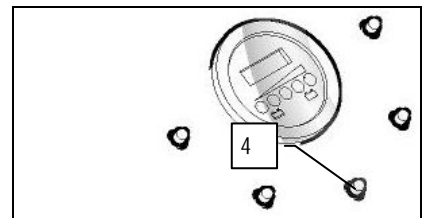

33. SIDE BRUSH HANDLING

This machine offers the option of using two side brushes which enable the transport of the dirt towards the centre of the machine. To do this, rotate the i-drive selector to the "D" position. To get them to return to their position, rotate the i-drive selector to the "C" position.

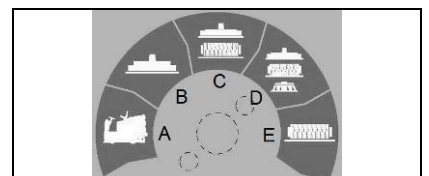



AT THE END OF THE WORK

34. •AT THE END OF WORK

At the end of the work, and before carrying out any type of maintenance, perform the following operations:

1. Fully rotate the tap lever (1) in a clockwise direction, completely closing the passage of the detergent solution.
2. Turn the I-DRIVE selector to the "Transfer" position. Both the brush head and the squeegee rise and after a few seconds the vacuum motor will turn off.
3. Bring the machine to the place provided for draining the water
4. Turn the machine off by turning the key a quarter turn anticlockwise (to the "0" position) and remove it from the instrument panel
5. Engage the parking brake
6. Raise the seat support plate and disconnect the electrical system connector from the battery connector
7. Release the clamp (2) and, keeping it pressed, pull on the handle (3) to remove the debris hopper; place it on the ground, then take it to the appropriate disposal point and empty it

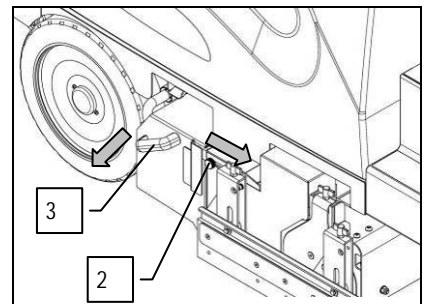
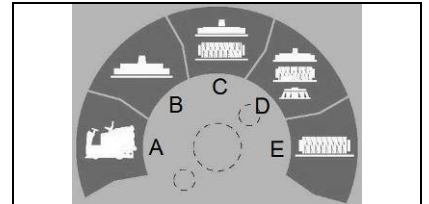
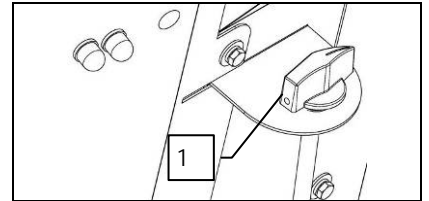

WARNING: this operation must be carried out by using gloves in order to protect against contact with dangerous solutions.

8. Insert the debris hopper in the machine and lock it using the clamp (2)



WARNING: Before performing any maintenance, remove the keys from the panel and disconnect the battery connector

9. Disconnect the recovery tank drainage tube (4) from its housing, unscrew the drainage cap and empty the recovery tank
10. Disconnect the solution tank drainage tube (5) from its housing, unscrew the drainage cap and empty the solution tank
11. Detach the vacuum hose from the nozzle on the squeegee body

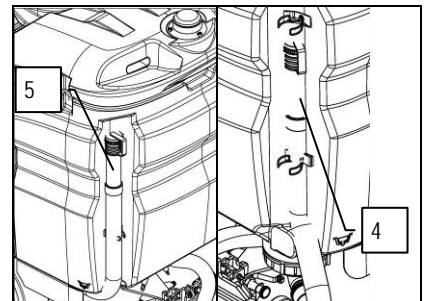

WARNING: this operation must be carried out by using gloves in order to protect against contact with dangerous solutions.

12. Remove the pins (6) for the squeegee rotation retainer. To remove it pull the knob towards the outside of the machine and turn it in anticlockwise direction
13. Remove the squeegee rotation retainer (7), lift it to remove it
14. Rotate the squeegee body in a clockwise direction and lock it in position using the pin (8)
15. Clean both the squeegee and the rubbers well, using a jet of water

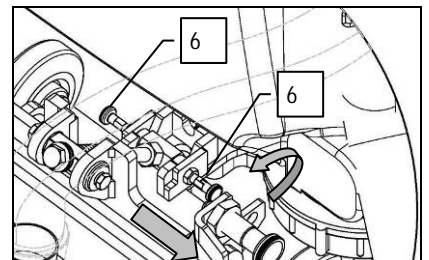

16. After cleaning the squeegee and rubbers, replace the squeegee by turning it anticlockwise, returning it to its original position, making sure that the squeegee rotation retainer (8) is returned to its normal position
17. Connect the electrical system connector to the battery connector, lower the seat support to the work position
18. Turn the machine on by turning the key a quarter turn clockwise (to the "1" position) and remove it from the instrument panel.
19. Disengage the parking brake.
20. Park the machine in a closed place, in an area where it cannot cause damage to people or other property, but also be protected from an accidental fall of objects.

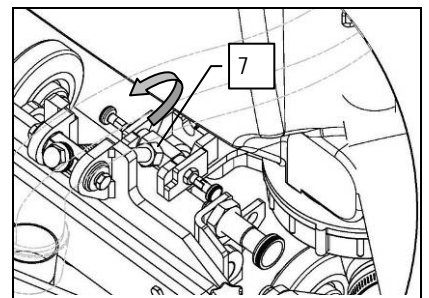



AT THE END OF THE WORK

21. Engage the parking brake
22. Turn the key switch a quarter turn anticlockwise (position "0") and remove the key
23. Raise the seat support and disconnect the electrical system connector from the battery connector



ATTENTION: do not leave the machine unattended without first removing the start-up switch key and applying the parking brake. In addition, do not park the machine in open places or on sloping floors .

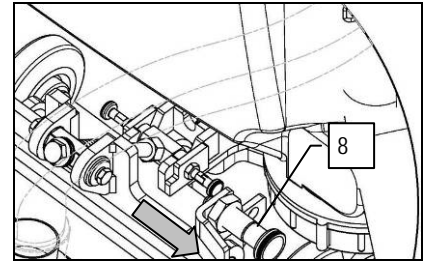



DAILY MAINTENANCE

PERFORM ALL MAINTENANCE OPERATIONS IN SEQUENCE

35. CLEANING THE VACUUM MOTOR FILTER

1. Check the recovery tank is empty (if necessary, empty it)
2. Check that the parking brake is engaged, and if not, engage it

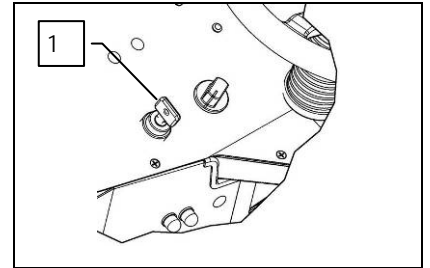

3. Check that the machine's main switch is on "OFF-0"; if this is not the case, turn the key of the main switch (1) a quarter of a turn anticlockwise (to the 0 position)
4. Grip the seat rotation uncoupling handle (2), move it forward as far as it will go
5. Rotate the seat support to the gas springs end stops

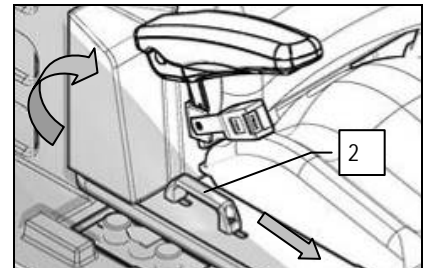

6. Disconnect the battery connector cable from the machine connector (3)
7. Rotate the seat support until it is back in the working position
8. Rotate the vacuum cap until the prop (4) fixed to the vacuum cap attaches to the prop (5) fixed to the recovery tank
9. Release the safety clip (6) from the hole that it is using when the vacuum cap is closed and insert it into the safety hole

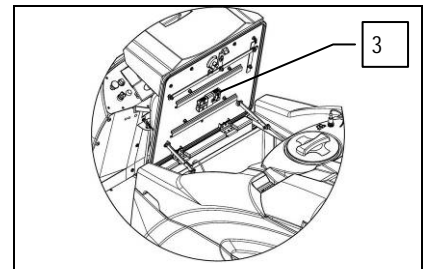

WARNING: These operations must be carried out using gloves to protect against contact with dangerous solutions.



WARNING: Prior to any sort of maintenance operation, remove the key from the panel and disconnect the battery connector (for battery versions) or from the generator connector (for versions with a combustion engine).

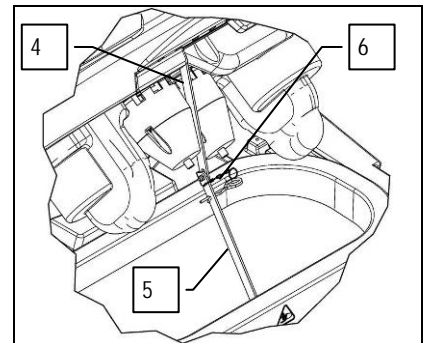

10. Remove the vacuum filter protection (7) by rotating it clockwise
11. Remove the retaining clips (8)
12. Remove the vacuum filter (9) from its seat
13. Use a jet of water to clean the walls and brush head of the filter
14. Perform steps 14 to 17 also for the second filter of the second vacuum motor
15. Reassemble all the elements

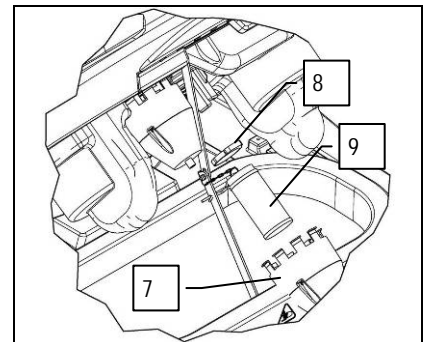



DAILY MAINTENANCE

36. CLEANING THE RECOVERY TANK

1. Check the recovery tank is empty (if necessary, empty it)
2. Check that the parking brake is engaged, and if not, engage it



WARNING: These operations must be carried out using gloves to protect against contact with dangerous solutions.



WARNING: Prior to any sort of maintenance operation, remove the key from the panel and disconnect the battery connector (for battery versions) or from the generator connector (for versions with a combustion engine).

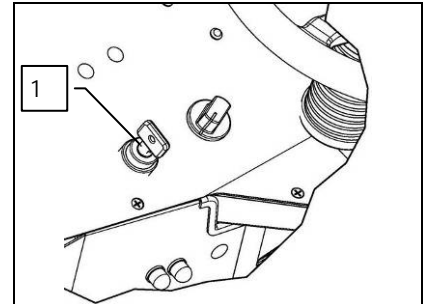

3. Check that the machine's main switch is on "OFF-0"; if this is not the case, turn the key of the main switch (1) a quarter of a turn anticlockwise (to the 0 position)
4. Grip the seat rotation uncoupling handle (2), move it forward as far as it will go
5. Rotate the seat support to the gas springs end stops

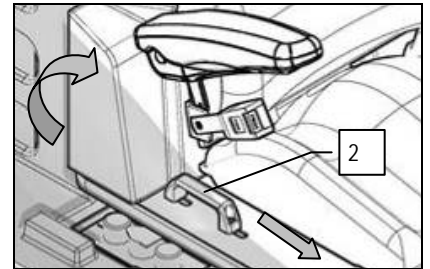

6. Grip the handle (3) moulded into the recovery tank
7. Rotate the recovery tank seat as far as it will go

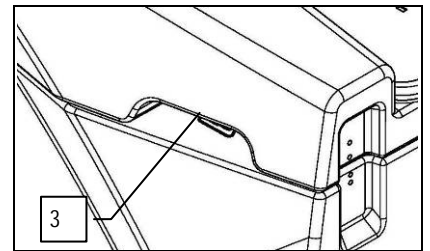

8. Rotate the vacuum cap until the prop (4) fixed to the vacuum cap attaches to the prop (5) fixed to the recovery tank
9. Release the safety clip (6) from the hole that it is using when the vacuum cap is closed and insert it into the safety hole

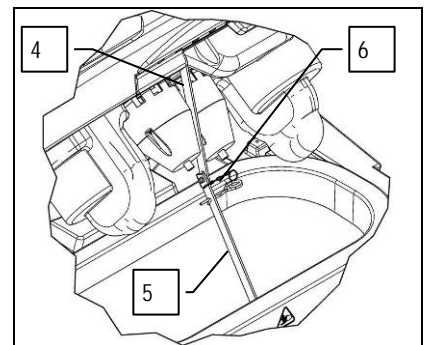

10. Check that the recovery tank drain pipe (7) is securely fastened to the machine, also check that the cap is closed
11. Unscrew the recovery tank drain hose cap (8) at the rear of the machine
12. Clean and rinse the recovery tank
13. Clean out and rinse the part of the recovery tank closest to the float switch (9) relating to the "RECOVERY TANK EMPTY" level
14. Reassemble all the elements

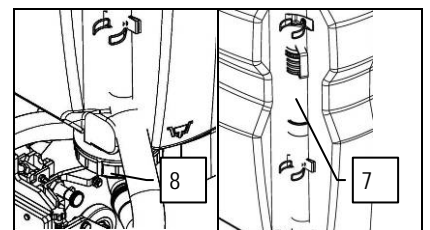

WARNING: These operations must be carried out using gloves to protect against contact with dangerous solutions.

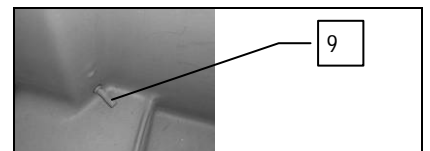



DAILY MAINTENANCE

37. CLEANING THE SQUEEGEE

The careful cleaning of the whole vacuum unit ensures better drying and cleaning of the floor as well as greater duration of the vacuum motor. Proceed as follows for cleaning:

1. Check that the parking brake is engaged, and if not, engage it
2. Check that the electrical system connector is disconnected from the battery connector, and if not, disconnect it
3. Check the main switch is on "0" (turn it to this position if necessary)
4. Disconnect the squeegee by loosening the knobs (1)
5. Clean the squeegee unit and the rubbers thoroughly with a jet of water, verify that there are no dirt residues in the vacuum chamber of the squeegee

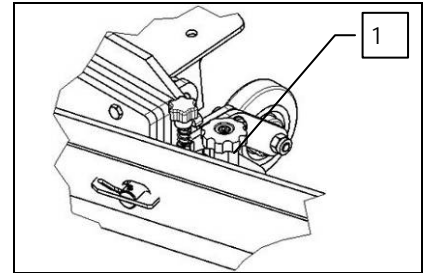

WARNING: this operation must be carried out by using gloves in order to protect against contact with dangerous solutions.

If the front rubber of the squeegee is worn, this will affect vacuum so the machine will not dry perfectly. If this is the case, replace the rubber (see REPLACING THE FRONT SQUEEGEE RUBBER). If the rear rubber of the squeegee is worn, this will affect vacuum so the machine will not dry perfectly. If this is the case, replace the rubber (see REPLACING THE REAR SQUEEGEE RUBBER).

After cleaning, replace the squeegee on its support:

1. Insert the squeegee left-hand pin into the left-hand slot of the squeegee support, secure it by means of the handwheel (1).
2. Insert the squeegee right-hand pin into the right-hand slot of the squeegee support, secure it by means of the handwheel (2).
3. Finally insert the squeegee tube in the special sleeve.



WARNING: These operations must be carried out using gloves to protect against contact with dangerous solutions.

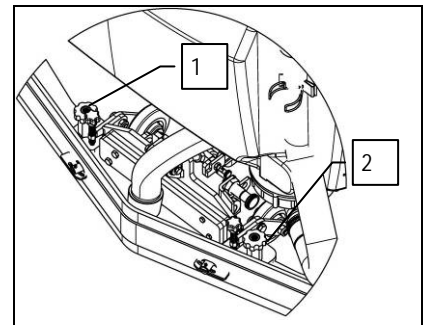

38. CLEANING THE SOLUTION TANK FILTER

Careful cleaning of the detergent/water solution filter ensures a better working capacity. Proceed as follows for cleaning:

1. Check that the parking brake is engaged, and if not, engage it
2. Check that the electrical system connector is disconnected from the battery connector, and if not, disconnect it
3. Check the main switch is on "0" (turn it to this position if necessary)
4. Open the filler cap (1)



WARNING: Before performing any maintenance, remove the keys from the panel and disconnect the battery connector

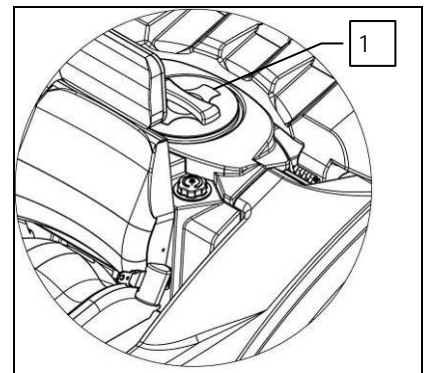

5. Disconnect the clean water drain hose from its housing at the rear of the machine, unscrew the cap and empty the tank.
6. Close the water tap.
7. Loosen the filter cap (2) on the front of the machine.
8. Remove the internal filter cartridge and rinse everything thoroughly with running water.
9. Reassemble all the elements.



WARNING: These operations must be carried out using gloves to protect against contact with dangerous solutions.

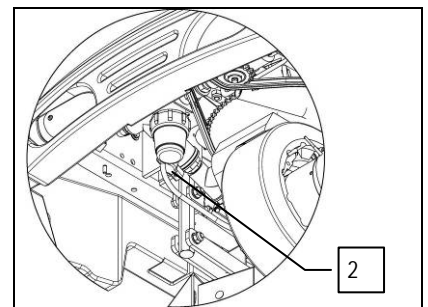



DAILY MAINTENANCE

39. CLEANING DEBRIS HOPPER AND HOPPER VACUUM FILTER

Correct cleaning of the debris hopper and the related filter ensures that the working capacity is enhanced.

Proceed as follows for cleaning:

1. make sure the recovery tank is empty, otherwise empty it completely
2. Check that the main switch of the machine is set to "0"
3. Ensure that the electrical system connector is disconnected from the battery connector

4. Check that the parking brake is engaged, otherwise engage it using the pedal (1)

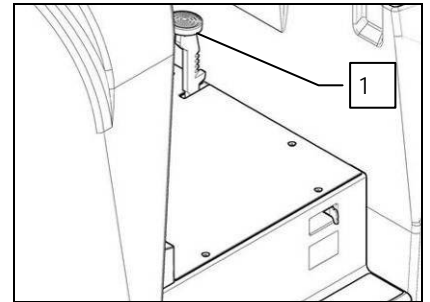

5. Release the clamp (2) and, keeping it pressed, pull on the handle (3) to remove the debris hopper; place it on the ground, then take it to the appropriate disposal point and empty it



WARNING: this operation must be carried out by using gloves in order to protect against contact with dangerous solutions.

6. Rinse the inside of the hopper with a jet of clean water

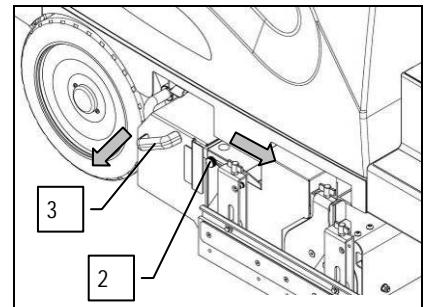

7. Remove the debris hopper vacuum filter (4) and clean it using a jet of running water

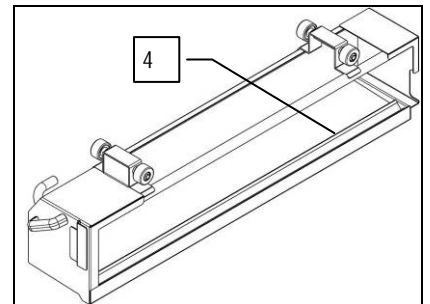

8. Release the clamp (2) and engage the debris hopper with the aid of the handle (3), attach the hopper clamp

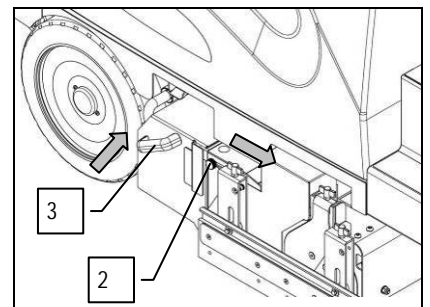



WEEKLY MAINTENANCE

40. CLEANING THE VACUUM HOSE

Whenever vacuum seems to be unsatisfactory, check that the vacuum hose is not obstructed. If necessary clean with a jet of water as follows:

1. Make sure the recovery tank is empty, otherwise empty it completely.
2. Check that the parking brake is engaged, and if not, engage it
3. Disconnect the suction hose from the squeegee nozzle (1)



WARNING: This operation must be carried out using gloves to protect against contact with dangerous solutions.

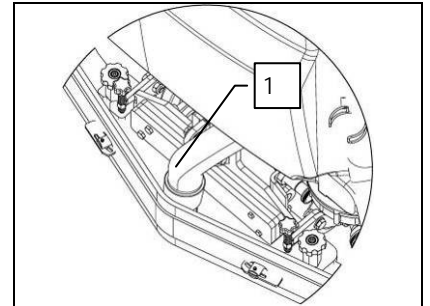

4. Turn the ignition key a quarter turn anticlockwise (position "0") and remove the key. Disconnect the battery connector cable from the machine connector.



WARNING: Before performing any maintenance, remove the keys from the panel and disconnect the battery connector

5. Grip the seat rotation uncoupling handle (2), move it forward as far as it will go
6. Rotate the seat support as far as it will go

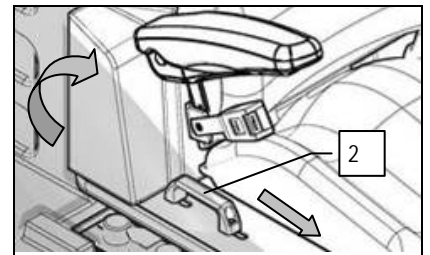

7. Rotate the vacuum cap until the prop (3) fixed to the vacuum cap attaches to the prop (4) fixed to the recovery tank
8. Release the safety clip (5) from the hole that it is using when the vacuum cap is closed and insert it into the safety hole

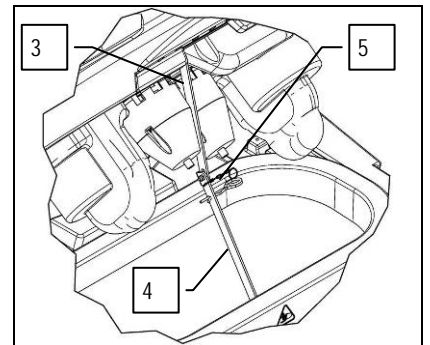

9. Release the clamp (6) and remove the debris hopper with the aid of the handle (7), place it on the ground

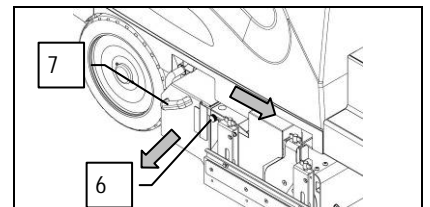

10. Clean it with a jet of running water inserted into the joint (8)
11. Reassemble all the elements

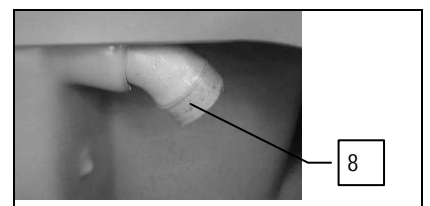



WEEKLY MAINTENANCE

41. CLEANING THE SOLUTION TANK

Proceed as follows for cleaning:

1. Check that the parking brake is engaged, and if not, engage it
2. Check that the electrical system connector is disconnected from the battery connector, and if not, disconnect it
3. Check the main switch is on "0" (turn it to this position if necessary)
4. Ensure the solution tank is empty, otherwise empty it



WARNING: Before performing any maintenance, remove the keys from the panel and disconnect the battery connector

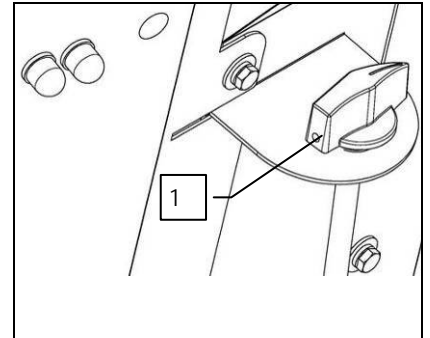

5. Close the water tap (1)
6. Disconnect the solution tank drainage hose (2) located at the rear of the machine
7. Unscrew the solution tank drainage hose cap

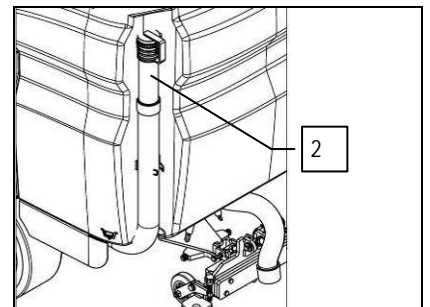

8. Unscrew the solution tank filling plug (3), located behind the operator's seat
9. rinse the inside of the tank with a jet of water
10. Refit all the parts



ATTENTION: These operations must be carried out using gloves to protect against contact with dangerous solutions.

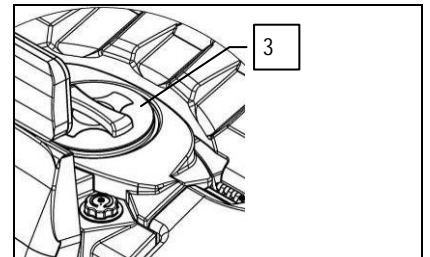

42. CYLINDRICAL BRUSH CLEANING

To assemble the cylindrical brushes of the brush head unit, proceed as follows:

1. Turn the key of the main switch (1) a quarter of a turn clockwise (to position 1).
2. Lift the brush head unit by operating the knob, the selected working program must be "Transport" (position A)
3. Turn the main switch key (1) anticlockwise by a quarter of a turn (to position 0).

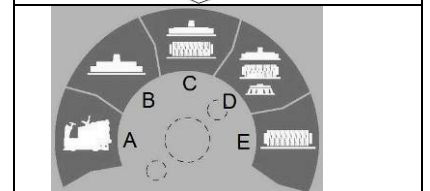
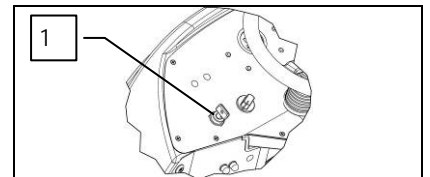

4. Engage the parking brake
5. Grip the seat rotation uncoupling handle (2), move it forward as far as it will go
6. Rotate the seat support as far as it will go
7. Disconnect the battery connector cable from the machine connector



WARNING: Before performing any maintenance, remove the keys from the panel and disconnect the battery connector

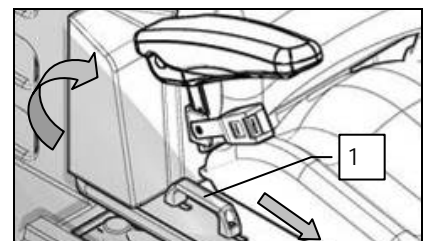



WEEKLY MAINTENANCE

8. Use a suitable tool to remove the splash guard pre-assembly (3), loosening the screws (4) that fix it to the brush head.

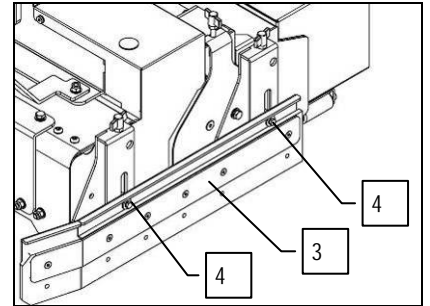

9. Remove the rear brush support (5), unscrew the knob (6) and place it on the ground.
10. Remove the rear brush from the tunnel (7) until it is placed on the ground, clean it using a jet of running water.

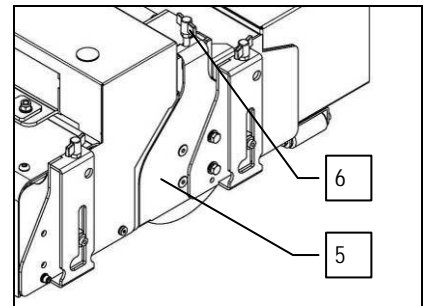

WARNING: you are advised to always wear protective gloves, to avoid the risk of serious injury to your hands.

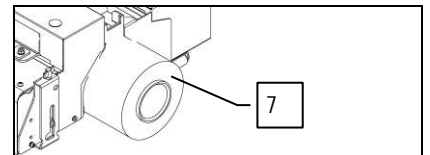

The phases which have been listed here refer to the assembly of the rear brush. Repeat for the front brush.

43. CLEANING THE SIDE BRUSH

Proceed as follows to wash the side brushes:

1. Turn the key of the main switch a quarter of a turn clockwise (to position 1).
2. Lift the brush head unit by operating the knob, the selected working program must be "Transport" (position A)
3. Turn the key of the main switch a quarter of a turn anticlockwise (to position 0).

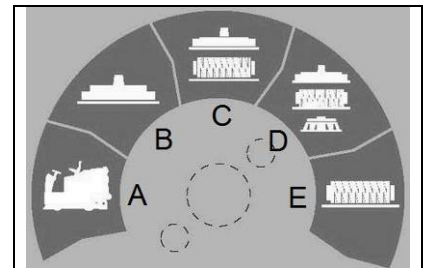

4. Engage the parking brake
5. Grip the seat rotation uncoupling handle (1), move it forward as far as it will go
6. Rotate the seat support as far as it will go
7. Disconnect the battery connector cable from the machine connector

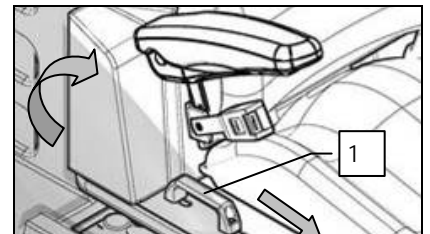

WARNING: Before performing any maintenance, remove the keys from the panel and disconnect the battery connector

8. With the brush-holder arm up, loosen the wing nut (2) and remove the washer (3).
9. Remove the brush from the housing of the hub, place it on the ground and clean it using a jet of running water.

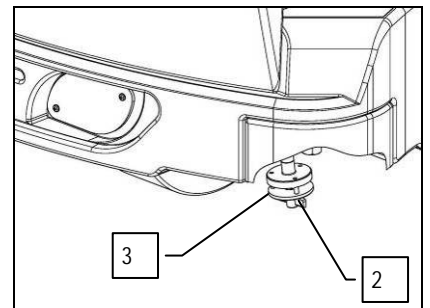

WARNING: You are advised to always wear protective gloves, to avoid the risk of serious injury to your hands.

The phases which have been listed here refer to the assembly of the left side brush. Repeat for the right side brush.



EXTRAORDINARY MAINTENANCE

44. REPLACING THE FRONT SQUEEGEE RUBBER

Suction will be poor and the machine will not dry perfectly if the front squeegee rubber is worn. Proceed as follows to replace:

1. Check that the parking brake is engaged, and if not, engage it
2. Check that the electrical system connector is disconnected from the battery connector, and if not, disconnect it
3. Check the main switch is on "0" (turn it to this position if necessary)



WARNING: Before performing any maintenance, remove the keys from the panel and disconnect the battery connector

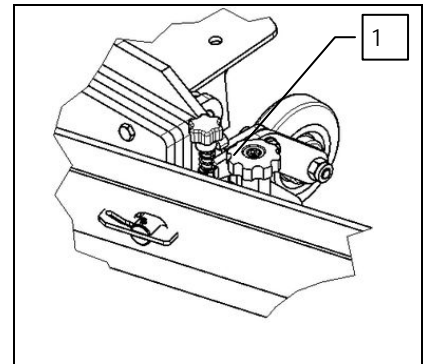

4. Disconnect the squeegee by loosening the knobs (1)
5. Using suitable equipment, undo the rubber-pressing blade securing screws (2)
6. Remove the rubber-pressing blade (3), then the rubber, for replacement
7. To replace the rubber, proceed in reverse order



WARNING: These operations must be carried out using gloves to protect against contact with dangerous solutions.

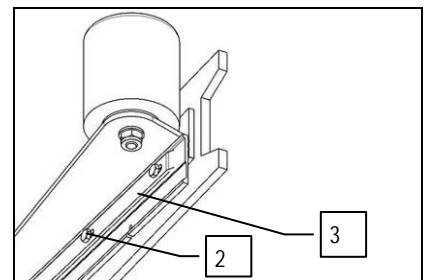

45. REPLACING THE REAR SQUEEGEE RUBBER

If the squeegee rear rubber is worn and does not dry well, it is possible to change the drying edge using one of the 4 edges of the rubber.

This can be done with the squeegee removed, proceeding as follows:

1. Check that the parking brake is engaged, and if not, engage it
2. Check that the electrical system connector is disconnected from the battery connector, and if not, disconnect it
3. Check the main switch is on "0" (turn it to this position if necessary)



WARNING: Before performing any maintenance, remove the keys from the panel and disconnect the battery connector

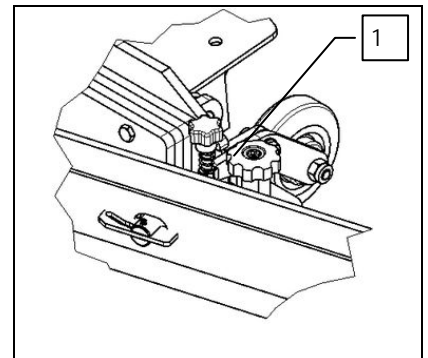

4. Disconnect the squeegee by loosening the knobs (1)
5. Rotate the fixing plates (2)
6. Remove the rubber-pressing blade (3) and then the rubber, to turn it over or replace it
7. To replace the rubber, proceed in reverse order
8. Adjust the height of the squeegee depending on the rubber (see "ADJUSTING THE SQUEEGEE SUPPORT HEIGHT")



WARNING: These operations must be carried out using gloves to protect against contact with dangerous solutions.

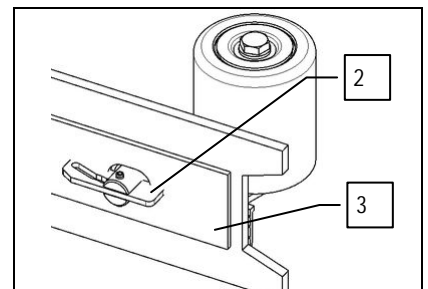

46. REPLACEMENT OF THE BRUSH HEAD SIDE SPLASH GUARD RUBBER

If the rubber on the side splash guard of the brush head is worn, its capacity to conduct water to the squeegee is compromised. The containment border can be replaced using one of the 2 edges of rubber. This operation can be done with the brush head carter removed, proceeding as follows:

1. Check that the parking brake is engaged, and if not, engage it
2. Check that the electrical system connector is disconnected from the battery connector, and if not, disconnect it
3. Check the main switch is on "0" (turn it to this position if necessary)



EXTRAORDINARY MAINTENANCE



WARNING: This operation must be carried out using gloves to protect against contact with dangerous solutions.

4. Use a suitable tool to remove the side splash guard (4), loosening the screws (2) that fix it to the rubber-pressing blade (3).



ATTENTION: The left side splash guard is depicted in the figure here, proceed in the same way when working on the right one.

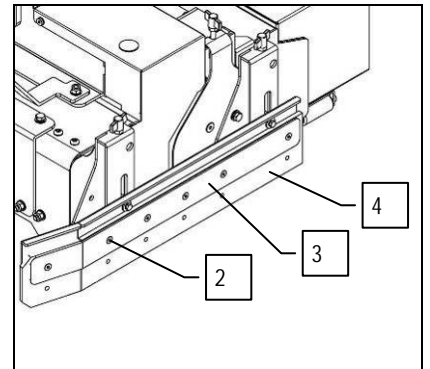

47. SIDE SPLASH GUARD HEIGHT ADJUSTMENT

If the side splash guard rubbers on the brush head are not positioned correctly in relation to the floor, these may not function properly (i.e. they may not conduct water to the squeegee correctly). The height of the splash guard rubbers must therefore be adjusted. This operation can be done with the brush head body in the work position, proceeding as follows:

1. Check that the parking brake is engaged, and if not, engage it
2. Check that the electrical system connector is disconnected from the battery connector, and if not, disconnect it
3. Check the main switch is on "0" (turn it to this position if necessary)
4. Turn the knobs (1) on the brush head body in a clockwise or anticlockwise direction



ATTENTION: When the knobs (1) are rotated in a clockwise direction, the side splash guards move away from the floor, while if the knobs (1) are rotated in an anticlockwise direction, the side splash guards move towards the floor.

5. Check that the rear splash guard rubber (2) is resting uniformly on the floor

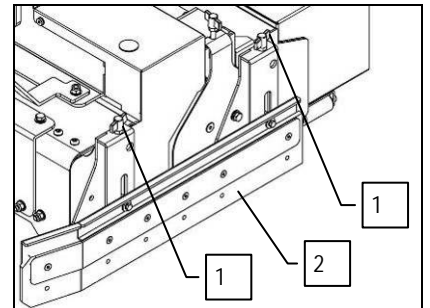

During working operation, the side splash guard rubber is slightly tilted outwards (by about 5mm) in a uniform way for its whole length.

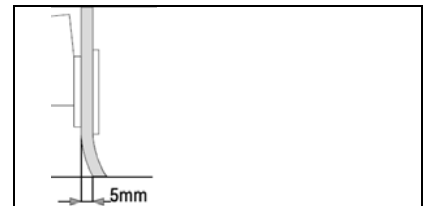

48. CLEANING THE DETERGENT SOLUTION SUPPLY PIPE

If the detergent solution supply pipe on the brush head unit is obstructed by dirt, it will not distribute the detergent solution uniformly on the floor. This will prevent the machine from functioning properly. To clean the basin proceed as follows:

1. Check that the brush head body is in the work position, otherwise turn the I-DRIVE selector to the "Scrubbing" position so that the brush head lowers
2. Ensure that the electrical system connector is disconnected from the battery connector
3. Make sure that the main switch is in the "0" position, if not turn the key a quarter turn to the left
4. Check that the parking brake is engaged, otherwise engage it using the pedal (1)

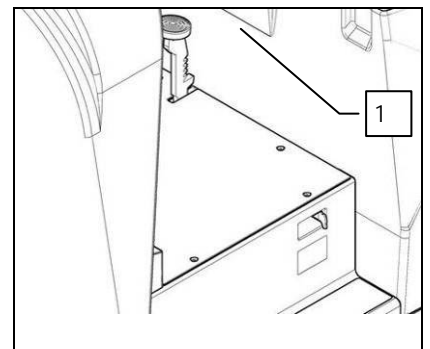



EXTRAORDINARY MAINTENANCE

5. Switch off the water tap by rotating the knob (2) in a clockwise direction

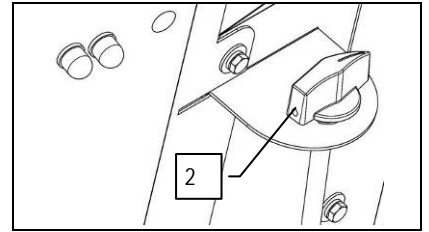

6. Using suitable equipment, remove the clamp (3) that fastens the rubber pipe (4) to the detergent solution pipe



WARNING: These operations must be carried out using gloves to protect against contact with dangerous solutions.

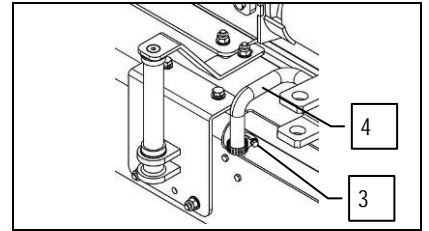

7. Using suitable equipment, remove the screws (5) that fasten the detergent solution pipe (6) to the brush head

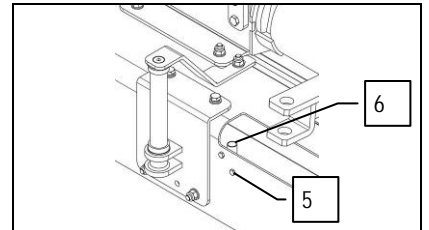

8. Remove the detergent solution supply pipe from the brush head body, pushing it towards the right side of the machine
9. Clean the detergent solution supply pipe using a jet of running water
10. Reassemble all the elements

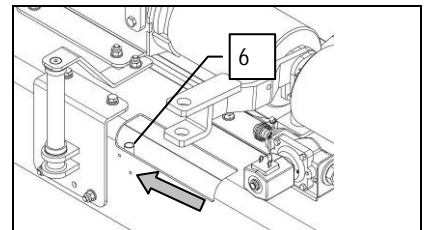



TROUBLESHOOTING

49. THE MACHINE DOES NOT START

1. Check that batteries are charged
2. Make sure the electric system connector is connected to the battery connector
3. Check the key switch is ON/I

50. INSUFFICIENT WATER ON THE BRUSHES

1. Check there is water in the solution tank
2. Check that the water/detergent solution release adjustment knob (1) is open
3. Clean the solution filter located at the front of the machine
4. Check that the detergent solution supply pipe, located on the brush head unit, is not obstructed

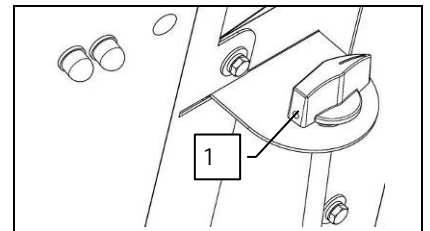

51. THE SQUEEGEE DOES NOT DRY PERFECTLY

1. Check the squeegee is clean
2. Check the squeegee settings (see "MACHINE PREPARATION")
3. Clean the entire vacuum unit (see "WEEKLY MAINTENANCE")
4. Replace the rubbers, if worn

52. THE MACHINE DOES NOT CLEAN WELL

1. Check the state of wear and tear of the brushes and, if necessary, replace them. The brushes should be changed when the bristles are about 15mm long. To replace them, see "REPLACING THE BRUSHES", or "DISASSEMBLING THE BRUSHES" and "ASSEMBLING THE BRUSHES". Working with over-worn brushes may cause damage to the floor.
2. Use a different kind of brush to the one fitted as standard. For cleaning floors where the dirt is particularly resistant, we recommend the use of special brushes supplied upon request and according to needs (see "CHOOSING AND USING THE BRUSHES").

53. EXCESSIVE FOAM PRODUCTION

Check that a low foam detergent has been used. If necessary, add a small quantity of antifoam liquid to the recovery tank.

Remember that, when the floor is not very dirty, more foam is generated. In this case the detergent solution should be more diluted.

54. THE VACUUM CLEANER DOES NOT FUNCTION

1. Check whether the recovery tank is full and, if necessary, empty it
2. Check the float on the vacuum cap (see also "CLEANING THE RECOVERY TANK" in the paragraph "DAILY MAINTENANCE")

55. THE BRUSH MOTOR DOES NOT WORK

ATTENTION To avoid damaging the floor, the motor only starts up when the machine is moved forwards

1. Check that the brush head is lowered during start-up
2. The operator must be properly seated in the driving position
3. Check no thermal protection device has intervened.
4. Check the correct connection of the motor to the terminal under the footboards.



TROUBLESHOOTING

56. ELECTRIC FUSES AND THERMAL CUT-OUTS

The machine is fitted with the following electrical protection systems:

Power fuses arranged in the electrical box, to protect against short-circuiting.
thermal trip units arranged on the outside of the handlebars, to protect the following motors:

1. 25 A trip unit for left vacuum motor
2. 25 A trip unit for right vacuum motor

In the event of malfunctioning, check a thermal cut-out has not intervened. If the motor overheats, its thermal cut-out intervenes to block the electricity supply. Wait a few minutes until it has cooled down, then press the specific trip unit button to reactivate the power supply and motor operation. If the problem persists, contact the specialist technical assistance centre.

57. THE AUTOMATIC WATER/DETERGENT DOSING SYSTEM DOES NOT WORK

The automatic water/detergent dosing system has been designed with criteria of extreme sturdiness and reliability, but there is a special by-pass system that allows you to use the machine even if the system is out-of-use.

To by-pass the automatic water/detergent dosing system, you must rotate the tap lever (1) on the front of the machine in an anti-clockwise direction; in this way you can go on working even with the system out-of-use. Remember, however, to put not only water in the solution tank, but the right quantities of both water and detergent. With the dosing system out-of-use, the water flow is regulated via the tap on the steering column. Contact an Authorised FIMAP Retailer to have the system repaired.

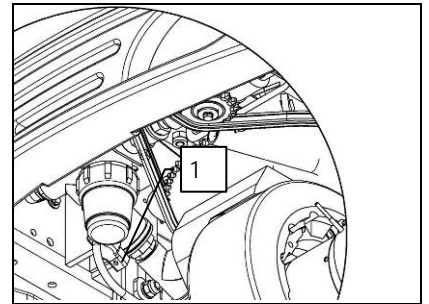

58. ALARMS

The machine is fitted with a flashing warning light (1) for diagnosing faults in the traction motor control system. Each sequence (number of consecutive flashes) indicates a particular type of fault. When flashing begins (with an accompanying working fault), you should contact the technical assistance centre, specifying the number of flashes.

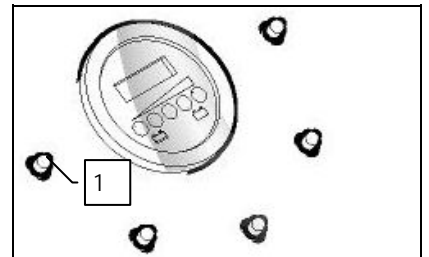



DISPOSAL

To dispose of the machine, take it to a demolition centre or an authorised collection centre.

Before scrapping the machine it is necessary to remove and separate the following materials and send them to the appropriate collection centres in accordance with the environmental hygiene regulations currently in force:

- brushes
- felt
- electric and electronic parts*
- batteries
- plastic parts (tanks and handlebars)
- metal parts (levers and frame)

(*) In particular, to scrap the electric and electronic parts, contact your area distributor.



CHOOSING AND USING THE BRUSHES

POLYPROPYLENE BRUSH (PPL)

Used on all types of floor, it has good resistance to wear and tear and hot water (no greater than 60°C). PPL is non-hygroscopic and therefore retains its characteristics even when working in wet conditions.

NYLON BRUSH

Used on all types of floors. Excellent resistance to wear and tear, and hot water (even over 60°C). The nylon is hygroscopic and so tends to lose its characteristics over time when working in wet conditions.

ABRASIVE BRUSH

The bristles of this type of brush are charged with highly aggressive abrasives. It is used to clean very dirty floors. To avoid floor damage, work only with the pressure strictly necessary.

THICKNESS OF THE BRISTLES

Thicker bristles are more rigid and are therefore used on smooth floors or floors with small joints.

On uneven floors or those with deep joints, it is advisable to use softer bristles which can enter the gaps more easily.

Remember that when the bristles are worn and therefore too short, they will become rigid and are no longer able to penetrate and clean deep down, also because, like with over-large bristles, the brush tends to jump.

PAD HOLDER

The pad holder is recommended for cleaning shiny surfaces.

There are two types of pad holder:

1. The traditional pad holder is fitted with a series of anchor points that allow the abrasive floor pad to be held and dragged while working.
2. The CENTER LOCK type pad holder not only has anchor points, but also a snap-type central locking system in plastic that allows the abrasive floor pad to be perfectly centred and held without any risk of it becoming detached. This type of holder is especially suitable for machines with several brushes, where the centring of the abrasive floor pads is difficult.

TABLE FOR CHOOSING THE BRUSHES

Machine	No. of brushes.	Code	Type of bristles	Ø Bristles	Ø Brush.	Length.	Notes
SMG130 S BASIC	2	414289	PPL	1	210	1012	Black cylindrical brush
		414290	ABRASIVE	-			Cylindrical brush
		411698	PPL		450		Disc brush
		411699	PPL + STEEL.				Disc brush



EC DECLARATION OF CONFORMITY

The undersigned manufacturer:
FIMAP S.p.A.
Via Invalidi del Lavoro, 1
37050 Santa Maria di Zevio (VR)
declares under its sole responsibility that the product

FLOOR SCRUBBING MACHINES SMG130 S BASIC

complies with the requirements of the following Directives:

- 2006/42/EC: Machinery Directive.
- 2006/95/EC: Low Voltage Directive.
- 2004/108/EC: Electromagnetic Compatibility Directive.

They also comply with the following standards:

- EN 60335-1: Household and similar electrical appliances - Safety. Part 1: Generic standards.
- EN 60335-2-72: Household and similar electrical appliances. Part 2: Generic standards for automatic machines for floor treatment for commercial and industrial use.
- EN 60335-2-29: Household and similar electrical appliances. Part 2: Special standards for battery chargers.
- EN 12100-1: Machine safety - Fundamental concepts, fundamental principles of design - Part 1: Basic terminology and methodology.
- EN 12100-2: Machine safety - Fundamental concepts, fundamental principles of design - Part 2: Technical principles.
- EN 61000-6-2: Electromagnetic compatibility (EMC) - Part 6-2: Generic standards – Immunity for industrial environments.
- EN 61000-6-3: Electromagnetic compatibility (EMC) - Part 6-3: Generic standards — Standard emission for residential, commercial and light-industrial environments.
- EN 61000-3-2: Electromagnetic compatibility (EMC) - Part 3-2: Limits – Limits for harmonic current emissions (Equipment with input current ≤ 16 A per phase).
- EN 61000-3-3: Electromagnetic compatibility (EMC) - Part 3-3: Limits – Restriction of voltage variations and flicker in low voltage power supply systems for devices with a rated current ≤ 16 A.
- EN 55014-1: Electromagnetic compatibility - Regulations for household appliances, electrical devices and similar equipment. Part 1: Emission - Regulation for product family.
- EN 55014-2: Electromagnetic compatibility - Regulations for household appliances, electrical devices and similar equipment. Part 2: Immunity - Regulation for product family.
- EN 62233: Household and similar electrical appliances - Electromagnetic fields Methods for evaluation and measurement.

The person authorised to compile the technical file:

Sig. Giancarlo Ruffo
Via Invalidi del Lavoro, 1
37050 Santa Maria di Zevio (VR) - ITALY

Santa Maria di Zevio, 20/09/2012

FIMAP S.p.A.
Legal representative
Giancarlo Ruffo

FIMAP spa
Via Invalidi del Lavoro, 1 - 37050 S.Maria di Zevio (Verona) Italy
Tel. +39 045 6060411 r.a. - Fax +39 045 6060417 - E-mail: fimap@fimap.com - www.fimap.com