

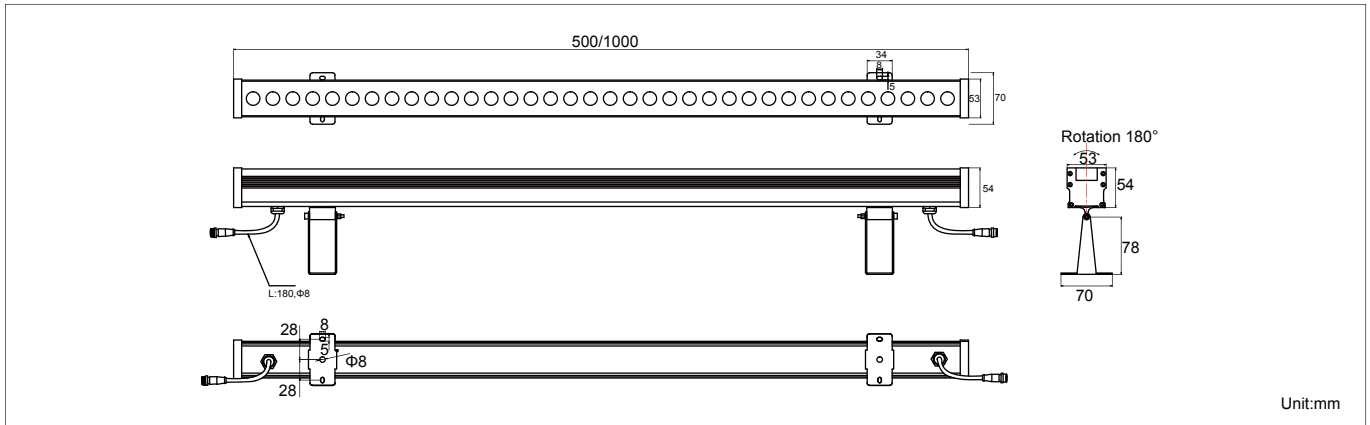

Product Dimensions:

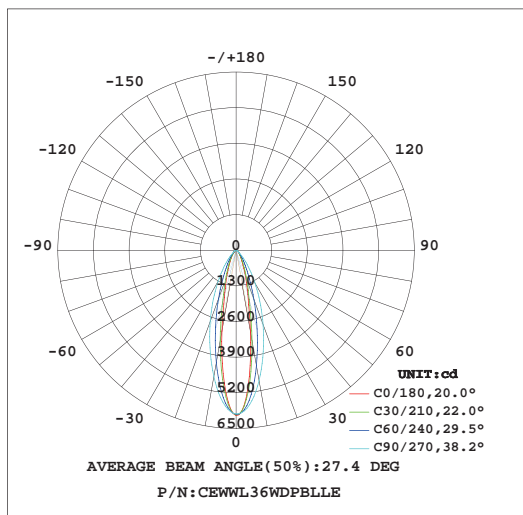

Luminous Intensity Distribution Diagram:



Lux Distribution:

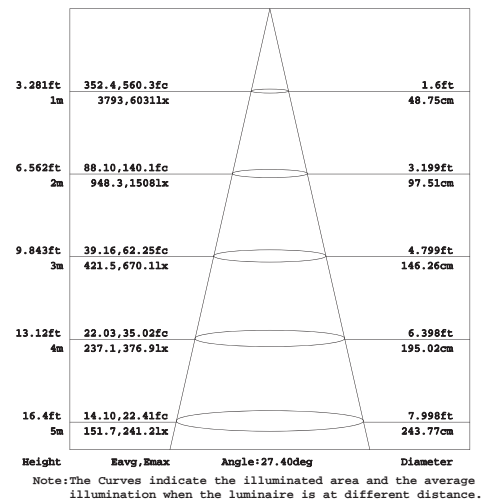

Manufacturing Quality Standard:

- ISO 9001:2008

LED Luminaire Standard:

- EN/IEC 60598-1
- EN/IEC 60598-2-1
- EN/IEC 60598-2-2
- EN/IEC 60529
- EN/IEC 62471-2
- IEC 62612
- EN/IEC 60968
- IEC 62560
- EN/IEC 60061-1
- EN 13032-1
- EN 13032-2
- EN/IEC 62471
- EN/IEC 60825
- EN 60061-1

Electronic Driver Standard:

- EN/IEC 61347-1
- EN/IEC 61347-2-13
- EN/IEC 62384
- EN/IEC 61000-3-2
- EN/IEC 61000-3-3
- EN/IEC 61547
- EN 55015(CISPR 15)

LED Module Standard:

- IEC 62031
- IEC 60838-2-2

LED Light Photometric Standard:

- CIE; TM14; LM-75; IES; LDT; CEN; CIB

RoHS Standard:

- EPA3050B
- EN 1122B
- IEC 62321
- EPA3052
- EPA3060A
- EPA7196A
- EPA3540C
- EPA8270D

LED Luminaire Performance:

- LM-80-08
- Switching cycle: 100,000x

Features:

- Comply with standard DMX 512(digital multiplex) controller system
- LED smart driver for DMX IP address for IP writing
- Frame per second:>100 FPS in DMX512 system
- Dimmable range:0~255 steps in dimming system
- #6063 aluminum alloy housing with anode oxidation
- Unique female/male connector IP65

Applications:

- Facade Lighting
- Building Outline
- Bridge Outline



Specifications:

Power	20W(500mm), 36W(1000mm)
Qty of LEDs	18PCSx1W(500mm), 36PCSx1W(1000mm)
Input Voltage	DC 24V or AC 85~264V 50/60Hz
Control Protocol	DMX 512 (optional)
Beam Angle	8°/15°/30°/45°/60°
Color Rendering Index	80
Luminaire Efficacy	* 75lm/w (2700K), * 80lm/w (3000K), * 90lm/w (4000K), * 95lm/w (5000K), * 100lm/w(6500K)
LED Source Efficacy	* 95lm/w (2700K), * 100lm/w (3000K), * 110lm/w (4000K), * 115lm/w (5000K), * 120lm/w (6500K)
Operating Temperature	-45~50°C
LED Sources	Cree / Taiwan Epistar
Life Time	50,000 Hours at Ta=40°C
Operating Humidity	10%~90%RH
Finishing Materials	Aluminum and Tempered Glass
Body Color	Matt Sliver
RAL Color Code	7040
Net Weight	1.8kg(500mm),2.8kg(1000mm)

Ordering Part No.:

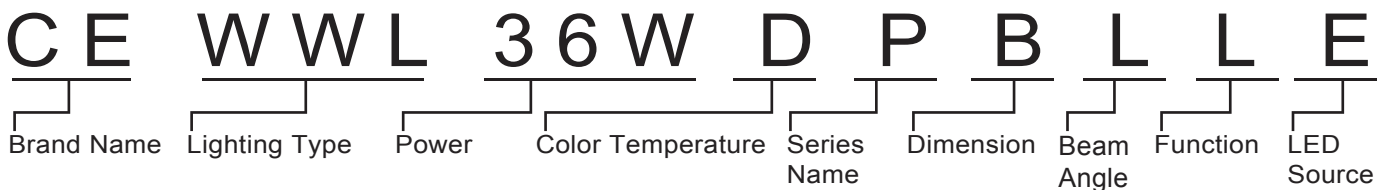

Brand Name	Lighting Type	Power	Color Temperature	Series Name	Dimension	Beam Angle	Function	LED Source
CE: CELEX	WWL: Wall Washer Light	20W 36W	O: 2700K W: 3000K N: 4000K D: 5000K C: 6500K R: Red(620~630nm) G: Green(520~530nm) B: Blue(450~460nm) Y: Yellow(590~595nm) F: Full Color(RGB)	P: PRYKE Series	A: 500mm B: 1000mm	S: 8° M: 15° L: 30° X: 45° W: 60°	D: DMX 512 L: DC 24V N: AC 85~264V T: Triac Dimming Leading Edge V: 1~10V Dimming	C: Cree E: Epistar

• System Diagram--Non dimming

(Typical wiring with T-Connector and I-Connector)

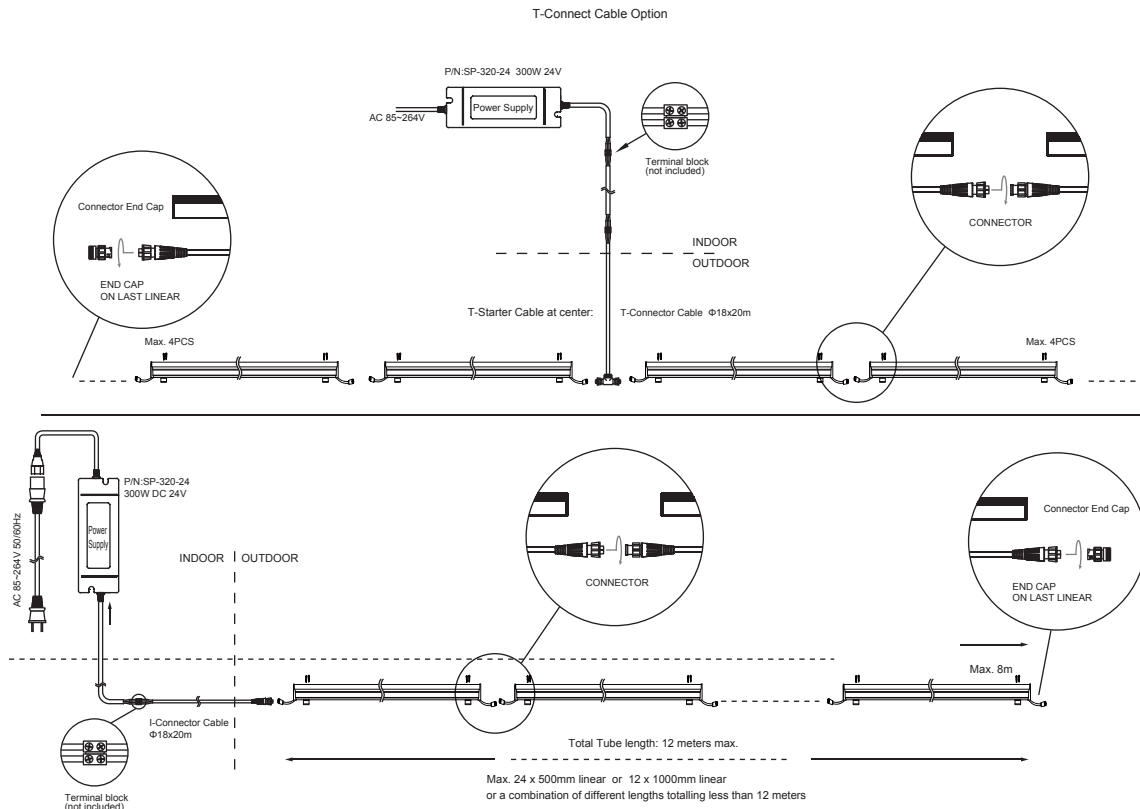

• System Diagram-DMX512-Dimming System or DMX512 Special Lighting System

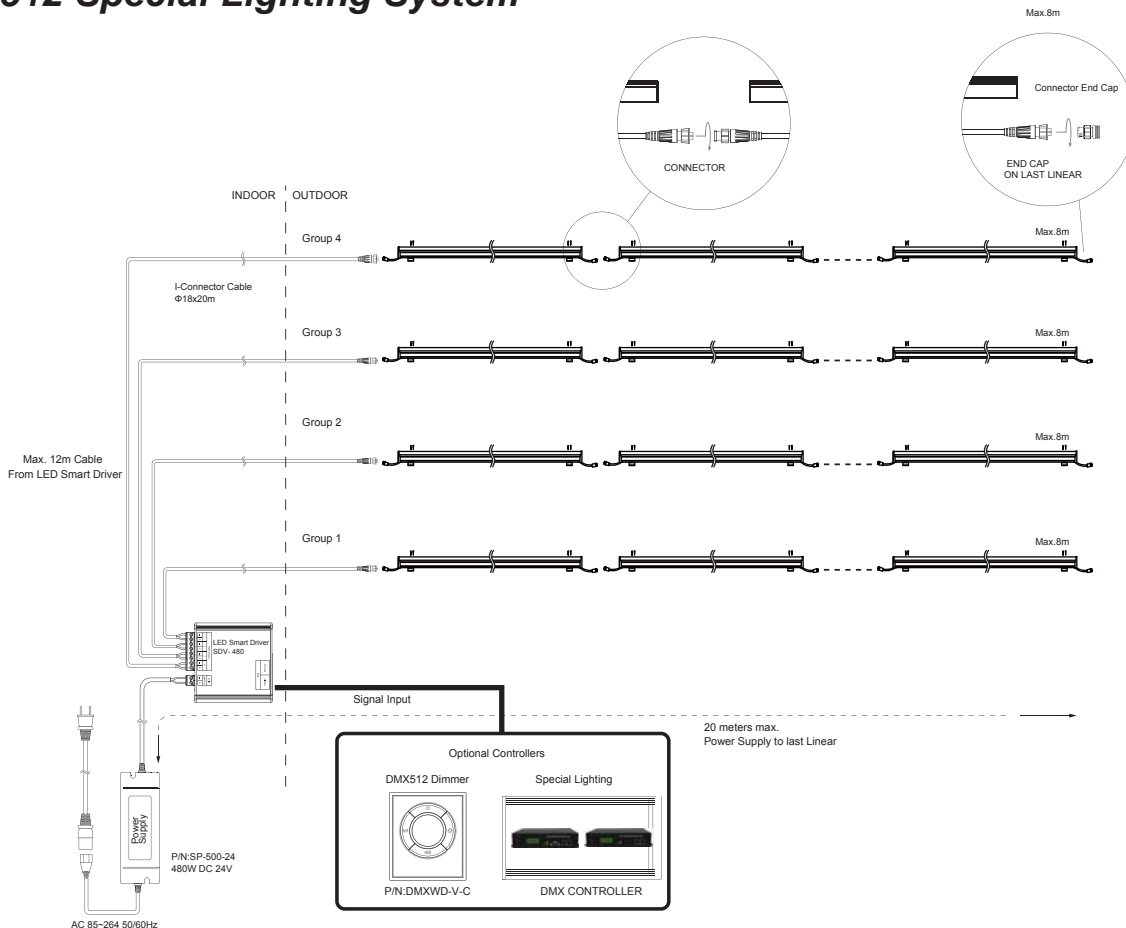

• Special Lighting DMX Controllers



P/N:DMXMC Master Controller



P/N:DMXSC Sub-Controller

• DMXMC & DMXSC Product Dimensions:

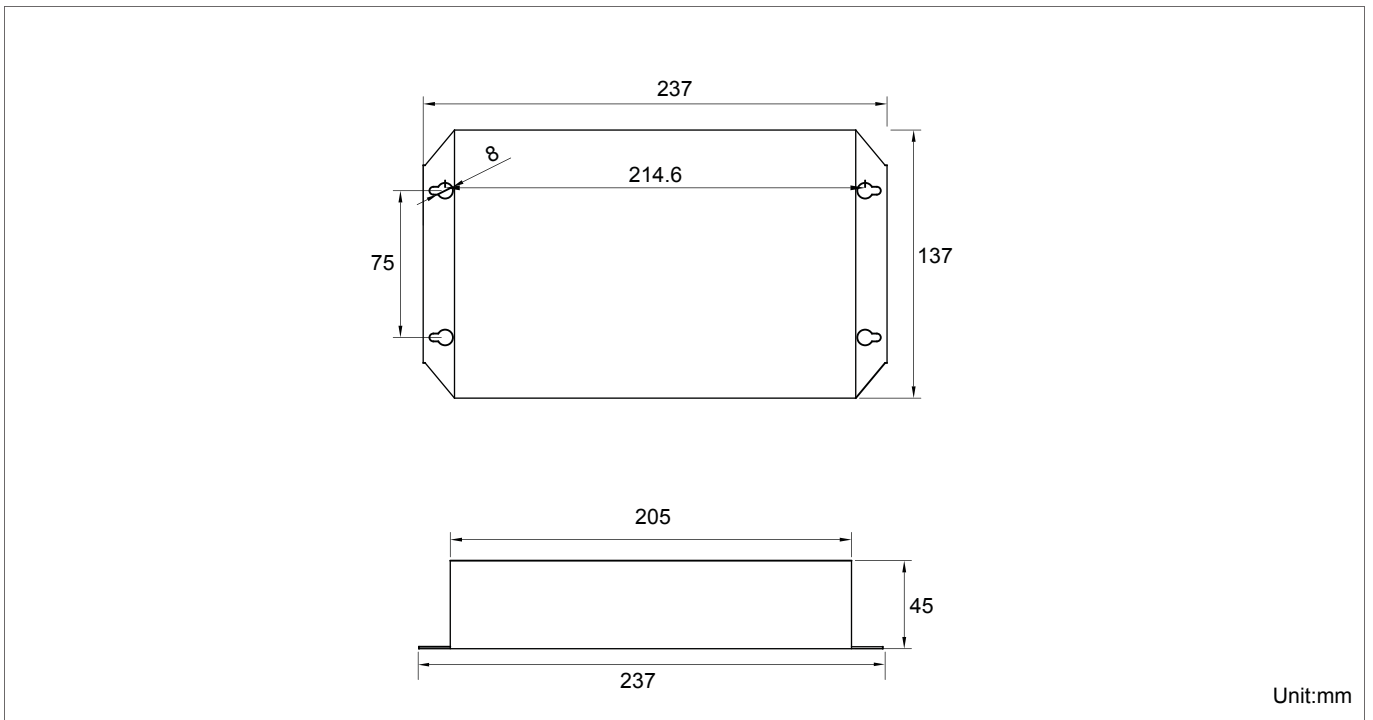



■ Features :

- Universal AC input / Full range
- Built-in active PFC function, PF>0.95
- Protections: Short circuit / Overload / Over voltage / Over temperature
- Forced air cooling by built-in DC Fan
- Built-in fan speed control
- Fixed switching frequency at 100KHz
- 3 years warranty



■ Specification

MODEL		SP-320-24		
OUTPUT	DC VOLTAGE	24V		
	RATED CURRENT	13A		
	CURRENT RANGE	0~13A		
	RATED POWER	300W		
	RIPPLE & NOISE (max.)	150mVp-p		
	VOLTAGE ADJ. RANGE	20~26.4V		
	VOLTAGE TOLERANCE	±1.0%		
	LINE REGULATION	±0.3%		
	LOAD REGULATION	±0.5%		
	SETUP, RISE TIME	800ms, 50ms/230VAC 2500ms, 50ms/115VAC at full load		
HOLD UP TIME (Typ.)	16ms/230VAC 16ms/115VAC at full load			
INPUT	VOLTAGE RANGE	88 ~ 264VAC 124 ~ 370VDC		
	FREQUENCY RANGE	47 ~ 63Hz		
	POWER FACTOR (Typ.)	PF>0.95/230VAC PF>0.98/115VAC at full load		
	EFFICIENCY (Typ.)	86%		
	AC CURRENT (Typ.)	115VAC	5A	
		230VAC	2.5A	
	INRUSH CURRENT (Typ.)	20A/115VAC 40A/230VAC		
	LEAKAGE CURRENT	<1mA / 240VAC		
PROTECTION	OVERLOAD	105 ~ 135% rated output power Protection type : Hiccup mode, recovers automatically after fault condition is removed		
	OVER VOLTAGE	27.6~32.4V Protection type : Shut down o/p voltage, re-power on to recover		
	OVER TEMPERATURE	80°C ±5°C (70°C ±5°C 3.3V,5V only) (TSW1 : detect on heatsink of power transistor) Protection type : Shut down o/p voltage, recovers automatically after temperature goes down		
ENVIRONMENT	WORKING TEMP.	-20 ~ +65°C (Refer to "Derating Curve")		
	WORKING HUMIDITY	20 ~ 90% RH non-condensing		
	STORAGE TEMP., HUMIDITY	-40 ~ +85°C, 10 ~ 95% RH		
	TEMP. COEFFICIENT	±0.03%/°C (0 ~ 50°C)		
SAFETY & EMC (Note 4)	VIBRATION	10 ~ 500Hz, 2G 10min./1cycle, 60min. each along X, Y, Z axes		
	SAFETY STANDARDS	UL60950-1, TUV EN60950-1, CCC GB4943(except for 3.3V, 36V) approved		
	WITHSTAND VOLTAGE	I/P-O/P:3KVAC I/P-FG:1.5KVAC O/P-FG:0.5KVAC		
	ISOLATION RESISTANCE	I/P-O/P, I/P-FG, O/P-FG:100M Ohms / 500VDC / 25°C / 70% RH		
	EMC EMISSION	Compliance to EN55022 (CISPR22) Class B, EN61000-3-2-3		
OTHERS	EMC IMMUNITY	Compliance to EN61000-4-2,3,4,5,6,8,11, EN55024, light industry level, criteria A		
	MTBF	207K hrs min. MIL-HDBK-217F (25°C)		
	DIMENSION	215*115*50mm (L*W*H)		
	PACKING	1.1Kg; 12pcs/14Kg/0.92CUFT		

Mechanical Specification

Case No. 912G Unit:mm

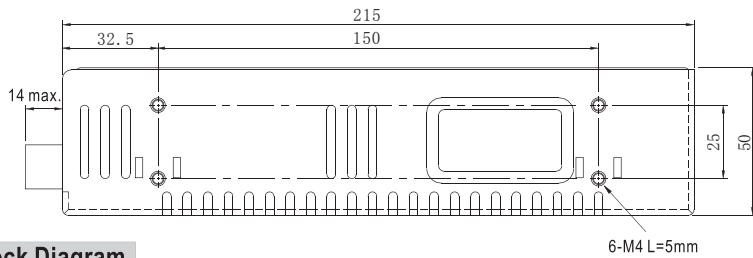
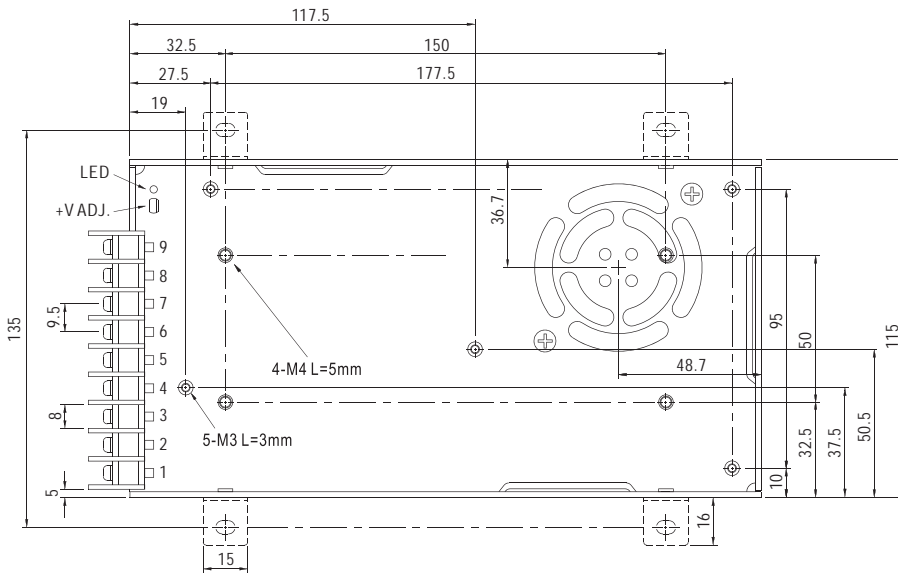

Terminal Pin No. Assignment :

Pin No.	Assignment	Pin No.	Assignment
1	AC/L	4~6	DC OUTPUT -V
2	AC/N	7~9	DC OUTPUT +V
3	FG		

Block Diagram

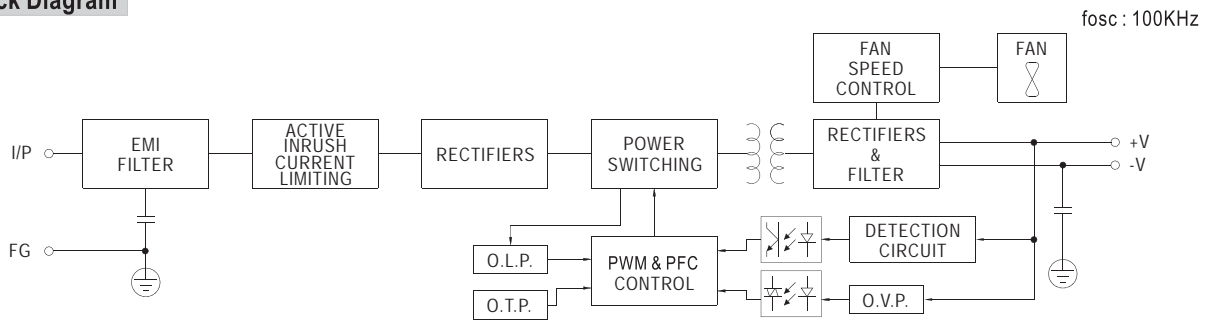

Derating Curve

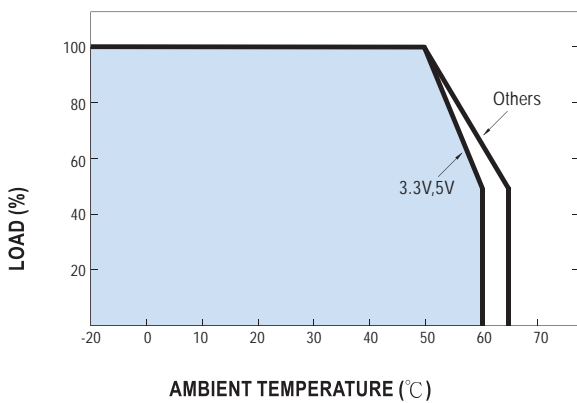

Static Characteristics

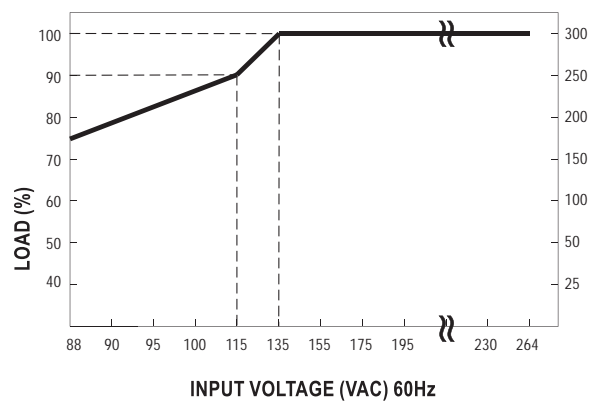

500W Single Output with PFC Function

SP-500 series



■ Features :

- Universal AC input / Full range
- Built-in active PFC function, PF>0.95
- Protections: Short circuit / Overload/ Over voltage / Over temperature
- Forced air cooling by built-in DC fan
- Built-in cooling Fan ON-OFF control
- Built-in remote ON-OFF control
- Built-in remote sense function
- 3 years warranty



SPECIFICATION

MODEL	SP-500-12	SP-500-13.5	SP-500-15	SP-500-24	SP-500-27	SP-500-48	
OUTPUT	DC VOLTAGE	12V	13.5V	15V	24V	27V	48V
	RATED CURRENT	40A	36A	32A	20A	18A	10A
	CURRENT RANGE	0 ~ 40A	0 ~ 36A	0 ~ 32A	0 ~ 20A	0 ~ 18A	0 ~ 10A
	RATED POWER	480W	486W	480W	480W	486W	480W
	RIPPLE & NOISE (max.) Note.2	240mVp-p	240mVp-p	240mVp-p	240mVp-p	200mVp-p	300mVp-p
	VOLTAGE ADJ. RANGE	10 ~ 13.2V	12 ~ 15V	13.5 ~ 18V	20 ~ 26.4V	24 ~ 30V	41 ~ 56V
	VOLTAGE TOLERANCE Note.3	±1.0%	±1.0%	±1.0%	±1.0%	±1.0%	±1.0%
	LINE REGULATION	±0.5%	±0.5%	±0.5%	±0.5%	±0.5%	±0.5%
	LOAD REGULATION	±0.5%	±0.5%	±0.5%	±0.5%	±0.5%	±0.5%
	SETUP, RISE TIME	1500ms, 50ms at full load					
HOLD UP TIME (Typ.)	24ms at full load						
INPUT	VOLTAGE RANGE Note.5	88 ~ 264VAC	124 ~ 370VDC				
	FREQUENCY RANGE	47 ~ 63Hz					
	POWER FACTOR (Typ.)	PF>0.95/230VAC PF>0.95/115VAC at full load					
	EFFICIENCY(Typ.)	84%	84%	83%	85.5%	86.5%	87%
	AC CURRENT (Typ.)	7A/115VAC	3.5A/230VAC				
	INRUSH CURRENT (Typ.)	18A/115VAC	36A/230VAC				
LEAKAGE CURRENT	<3.5mA/240VAC						
PROTECTION	OVERLOAD	105 ~ 135% rated output power Protection type : Constant current limiting, recovers automatically after fault condition is removed					
	OVER VOLTAGE	13.8 ~ 16.2V	15.5 ~ 18.2V	18 ~ 21V	27.6 ~ 32.4V	31 ~ 36.5V	57.6 ~ 67.2V
	FAN CONTROL, O.T.P.	RTH1 or RTH2 ≥ 50°C FAN ON, ≤ 45°C FAN OFF, ≥ 70°C output shutdown					
FUNCTION	REMOTE CONTROL	RC+/RC-: Short = power on ; Open = power off					
ENVIRONMENT	WORKING TEMP.	-10 ~ +50°C (Refer to "Derating Curve")					
	WORKING HUMIDITY	20 ~ 90% RH non-condensing					
	STORAGE TEMP., HUMIDITY	-20 ~ +85°C, 10 ~ 95% RH					
	TEMP. COEFFICIENT	±0.03%/°C (0 ~ 50°C)					
	VIBRATION	10 ~ 500Hz, 2G 10min./1cycle, period for 60min. each along X, Y, Z axes					
SAFETY & EMC (Note 4)	SAFETY STANDARDS	UL60950-1, TUV EN60950-1 approved					
	WITHSTAND VOLTAGE	I/P-O/P:3KVAC I/P-FG:2KVAC O/P-FG:0.5KVAC					
	ISOLATION RESISTANCE	I/P-O/P, I/P-FG, O/P-FG:100M Ohms / 500VDC / 25°C / 70% RH					
	EMC EMISSION	Compliance to EN55022 (CISPR22) Class B, EN61000-3-2,-3					
OTHERS	EMC IMMUNITY	Compliance to EN61000-4-2,3,4,5,6,8,11, light industry level, criteria A					
	MTBF	133.4K hrs min. MIL-HDBK-217F (25°C)					
	DIMENSION	170*120*93mm (L*W*H)					
NOTE	PACKING	1.9Kg; 8pcs/15.5Kg/1.06CUFT					
		1. All parameters NOT specially mentioned are measured at 230VAC input, rated load and 25°C of ambient temperature. 2. Ripple & noise are measured at 20MHz of bandwidth by using a 12" twisted pair-wire terminated with a 0.1uf & 47uf parallel capacitor. 3. Tolerance : includes set up tolerance, line regulation and load regulation. 4. The power supply is considered a component which will be installed into a final equipment. The final equipment must be re-confirmed that it still meets EMC directives. For guidance on how to perform these EMC tests, please refer to "EMI testing of component power supplies." (as available on http://www.meanwell.com) 5. Derating may be needed under low input voltages. Please check the derating curve for more details.					

500W Single Output with PFC Function

SP-500 series

Mechanical Specification

Case No. 910 Unit:mm

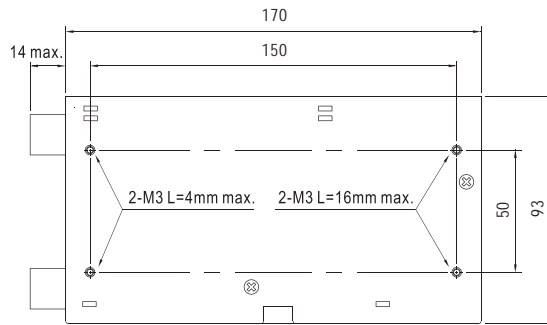
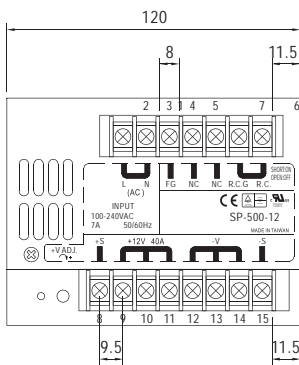
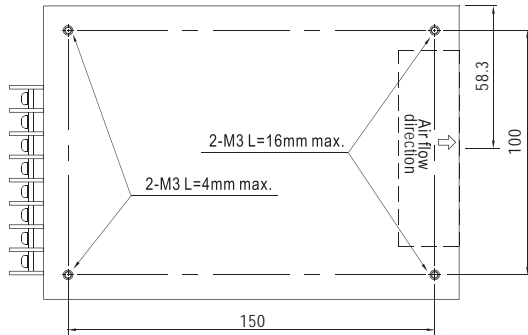

Terminal Pin No. Assignment

Pin No.	Assignment	Pin No.	Assignment
1	AC/L	7	R.C.
2	AC/N	8	+S
3	FG	9-11	DC OUTPUT +V
4,5	NC	12-14	DC OUTPUT -V
6	R.C.G	15	-S

Block Diagram

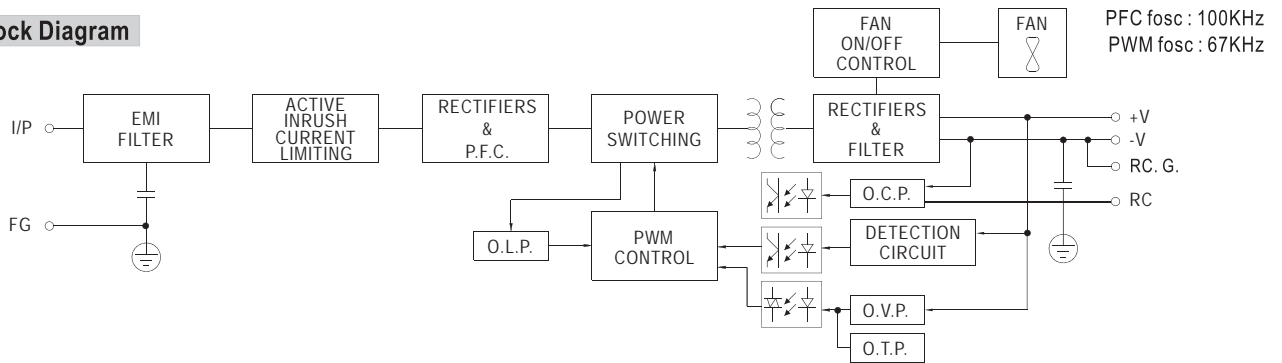

Derating Curve

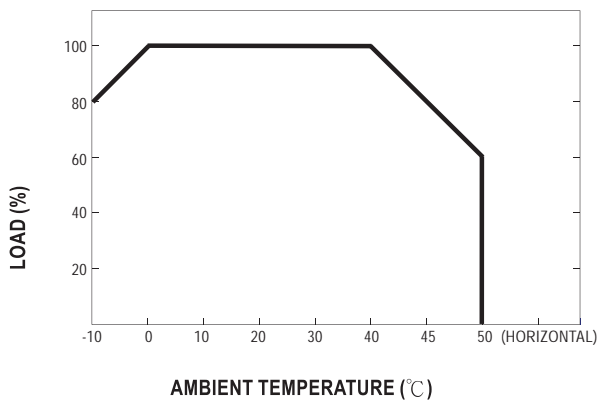

Output Derating VS Input Voltage

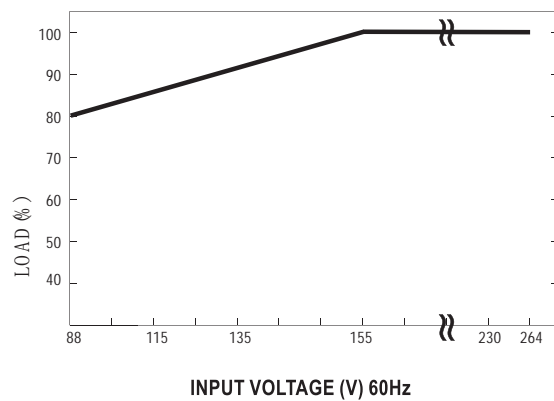

LED Wall Washer Light PRYKE Series



DMX Architectural Effect:



LED Wall Washer Light PRYKE Series