

Product Dimensions:

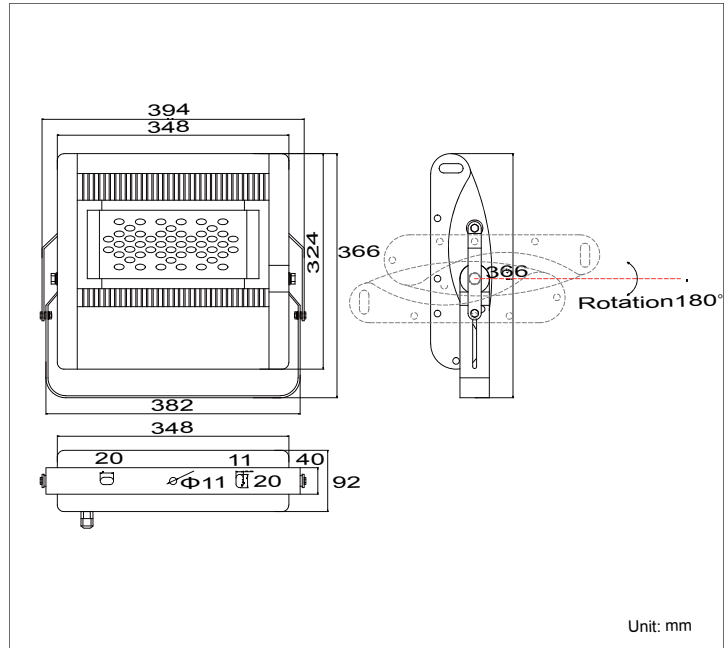

Luminous Intensity Distribution Diagram & Lux Distribution:

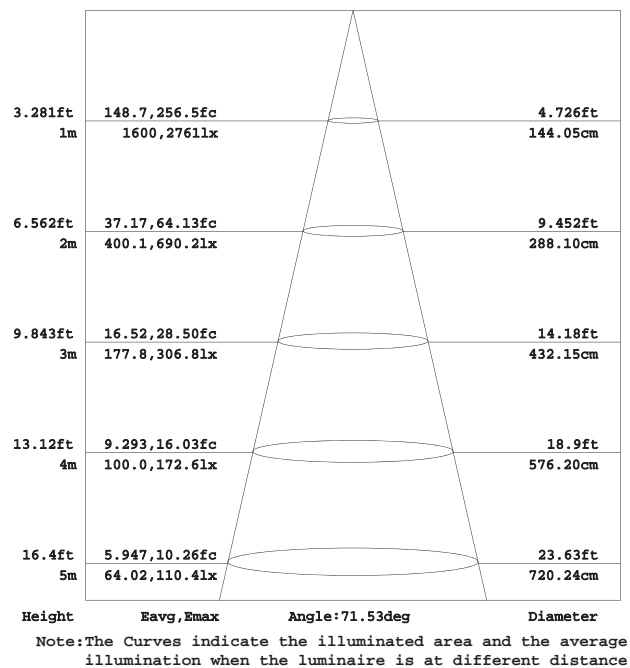
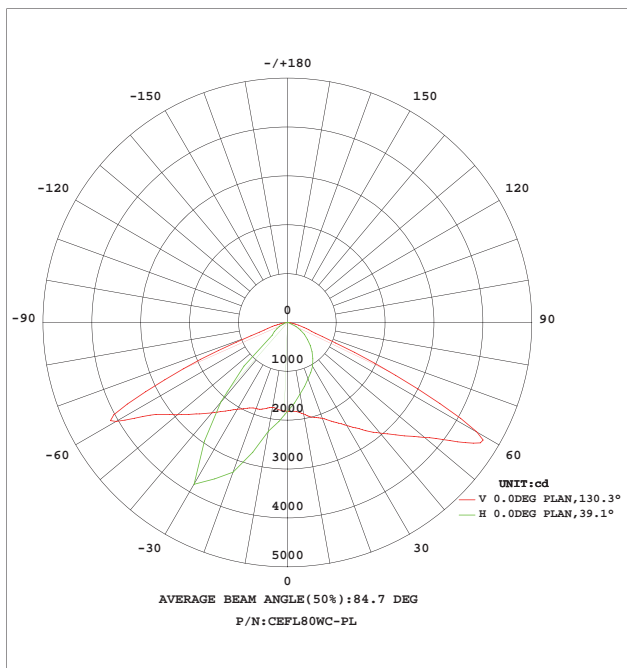

Manufacturing Quality Standard:

- ISO 9001:2008

LED Luminaire Standard:

- EN/IEC 60598-1
- EN/IEC 60598-2-1
- EN/IEC 60598-2-2
- EN/IEC 60529
- EN/IEC 62471-2
- IEC 62612
- EN/IEC 60968
- IEC 62560
- EN/IEC 60061-1
- EN 13032-1
- EN 13032-2
- EN/IEC 62471

Electronic Driver Standard:

- EN/IEC 61347-1
- EN/IEC 61347-2-13
- EN/IEC 62384
- EN/IEC 61000-3-2
- EN/IEC 61000-3-3
- EN/IEC 61547
- EN 55015(CISPR 15)

LED Module Standard:

- IEC 62031
- IEC 60838-2-2

LED Light Photometric Standard:

- CIE; TM14; LM-75; IES; LDT; CEN; CIB

RoHS Standard:

- EPA3050B
- EN 1122
- IEC 62321
- EPA3052
- EPA3060A
- EPA7196A
- EPA3540C
- EPA8270C

LED Luminaire Performance:

- LM-80-08
- Switching cycle:100,000x

## Features:

- Can replace 200W high pressure sodium or HID lamp
- Fold-Fin Heatsink (FFH) technology
  - Formed by thin aluminum sheets and pressed into the desired fin structures by fully automated machines
  - Different parts of heatsink are then soldered together via a high temperature furnace
  - Resulting in a heatsink with large total surface area and extremely light weight
- Air ventilation housing design
  - The housing is designed in a way to allow very effective air flow across the heatsink
  - It helps to bring the heat away from LED light source by natural convection
- Distributed heat source
  - Distributed light source panel configuration to spread the heat source over large area
  - Greatly reduced thermal density helps to lower the LED junction temperature

## Applications:

- Billboard and decorative lighting
- Outline of buildings
- Walls
- Bridges



## Specifications:

Part No	CCT (K)	Average Beam Angle	Color Rendering Index	Luminous Intensity (cd)	Luminaire Luminous Flux (lm)	Luminaire Efficacy (lm/w)	Power (w)
CEFL80WW-PS	3000	12°/12° (Horizontal)/(Vertical)	80	24000	7000	95	80
CEFL80WN-PS	4000	12°/12° (Horizontal)/(Vertical)	80	26000	7300	100	80
CEFL80WC-PS	6500	12°/12° (Horizontal)/(Vertical)	80	30000	7700	110	80
CEFL80WW-PM	3000	30°/30° (Horizontal)/(Vertical)	80	12000	7000	95	80
CEFL80WN-PM	4000	30°/30° (Horizontal)/(Vertical)	80	13000	7300	100	80
CEFL80WC-PM	6500	30°/30° (Horizontal)/(Vertical)	80	15000	7700	110	80
CEFL80WW-PL	3000	130°/60° (Horizontal)/(Vertical)	80	4200	7000	95	80
CEFL80WN-PL	4000	130°/60° (Horizontal)/(Vertical)	80	4900	7300	100	80
CEFL80WC-PL	6500	130°/60° (Horizontal)/(Vertical)	80	5300	7700	110	80
CEFL80WW-PW	3000	135°/85° (Horizontal)/(Vertical)	80	3900	7000	95	80
CEFL80WN-PW	4000	135°/85° (Horizontal)/(Vertical)	80	4200	7300	100	80
CEFL80WC-PW	6500	135°/85° (Horizontal)/(Vertical)	80	4500	7700	110	80

## General And Electrical Characteristics:

- Input Voltage: AC 100~240V(50/60Hz)
- Power Factor: 0.95
- Total Harmonic Distortion: 10%
- Operating Temperature: -20~50°C
- Operation Humidity: 10~95%RH
- LED Source: Philips Luxeon
- Life Time: 50,000 Hours (Ta=40°C)
- Finishing Materials: Aluminum / Tempered Glass
- Body Color: Black
- Net Weight: 6.3kg
- Packing Size: 400x430x170mm

