

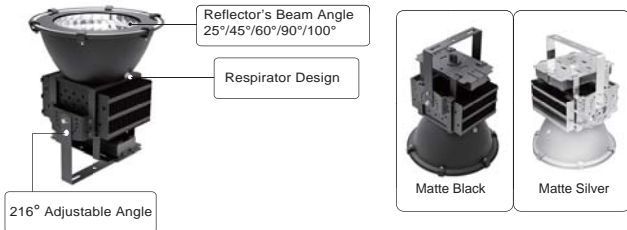

Product Dimensions:

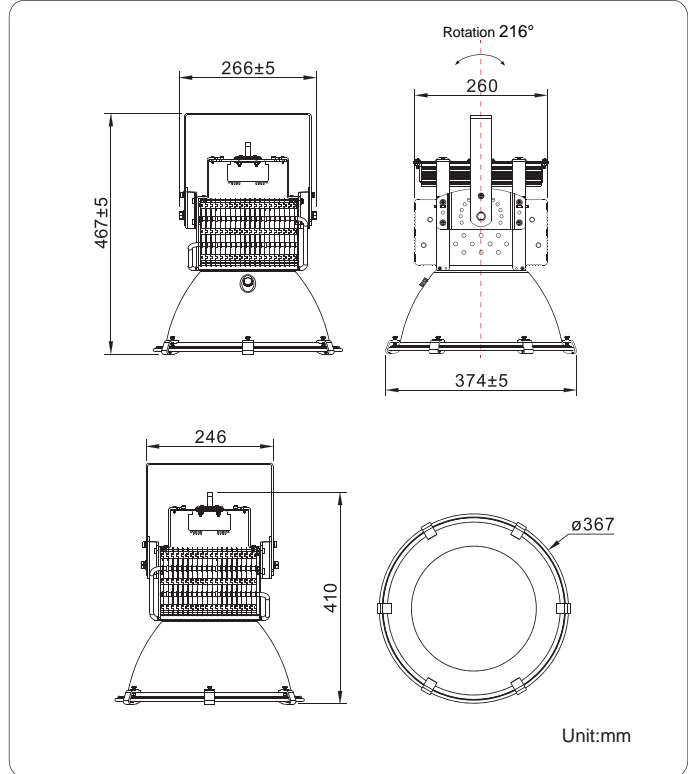

Luminous Intensity Distribution Diagram:

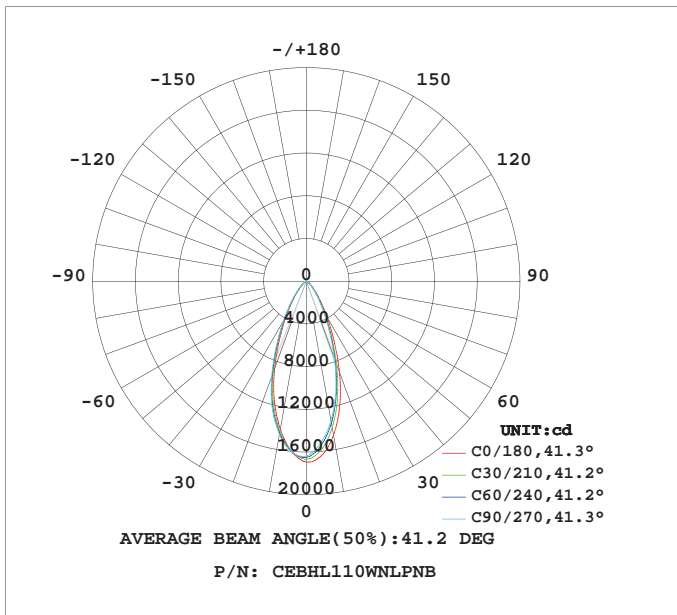

Lux Distribution:

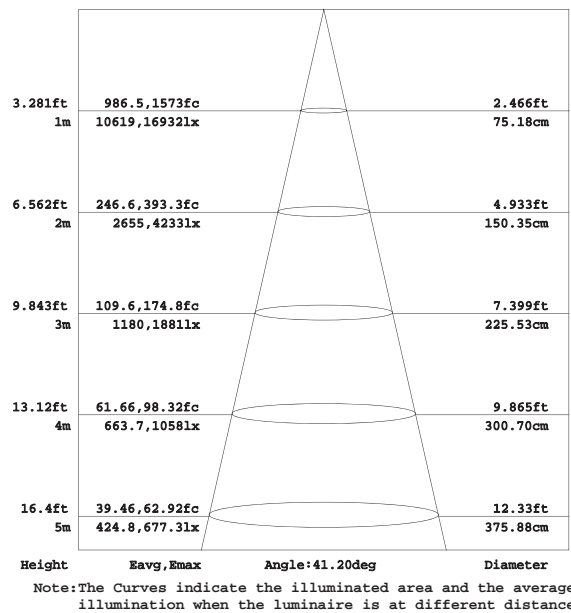

Manufacturing Quality Standard:

- ISO 9001:2008
- LED Luminaire Standard:**
  - EN/IEC 60598-1
  - EN/IEC 60598-2-1
  - EN/IEC 60598-2-2
  - EN/IEC 60529
  - EN/IEC 62471-2
  - IEC 62612
  - EN/IEC 60968
  - IEC 62560
  - EN/IEC 60061-1
  - EN 13032-1
  - EN 13032-2
  - EN/IEC 62471
  - EN/IEC 60825
  - EN 60061-1

Electronic Driver Standard:

- EN/IEC 61347-1
- EN/IEC 61347-2-13
- EN/IEC 62384
- EN/IEC 61000-3-2
- EN/IEC 61000-3-3
- EN/IEC 61547
- EN 55015(CISPR 15)

LED Module Standard:

- IEC 62031
- IEC 60838-2-2

LED Light Photometric Standard:

- CIE; TM14; LM-75; IES; LDT; CEN; CIB

RoHS Standard:

- EPA3050B
- EN 1122B
- IEC 62321
- EPA3052
- EPA3060A
- EPA7196A
- EPA3540C
- EPA8270D

LED Luminaire Performance:

- LM-80-08
- Switching cycle:100,000x



## Features:

- Anode oxidized 1060 aluminum heatsink fins and clear tempered glass with 93% transparent
- Copper heatpipe in-side to conduct heat rapidly from chips bottom to the fins, greatly lower down the temperature of light source
- The entire housing coated by electrophoretic plait, excellent corrosion resistance
- Respirator design for Waterproof design, eliminating mist, avoiding condensation, improving quality, extending the life span
- Stainless steel screws and parts
- The symmetrical beam light distribution is suitable especially for the illumination of building
- Reflector made of anodized pure aluminum with 92% reflective rate
- Protected against dust entry and water jets IP65
- Built-in IP67 class II Meanwell LED driver complied with UL, CSA, TUV and EMC standard
- High power factor (>0.95) and power efficiency design

## Applications:

- Warehouse
- Production and logistic workshops
- Car Park



## Specifications:

Power	110W / 120W
Input Voltage	AC 100~240V 50/60Hz
Power Factor	>0.95
Dimming Control	Triac Leading Edge / DMX 512 / 0~10V / Dali
Beam Angle	25° / 45° / 60° / 90° / 100°
Color Rendering Index	>80
Luminaire Efficacy	* 90lm/w (3000K), *100lm/w (4000K), * 105lm/w (5000K), * 105lm/w (6500K)
LED Source Efficacy	* 100lm/w (3000K), * 110lm/w (4000K), * 125lm/w (5000K), * 125lm/w (6500K)
Operating Temperature	-20°C~70°C
LED Source	CREE
Life Time	50,000 Hours
Operating Humidity	0~99%RH
Finishing Materials	Aluminum and Tempered Glass
Body Color	Matte Black / Matte Silver
RAL Color Code	RAL 9004 / RAL 9006
Net Weight	6.3kg

## Ordering Part No.:

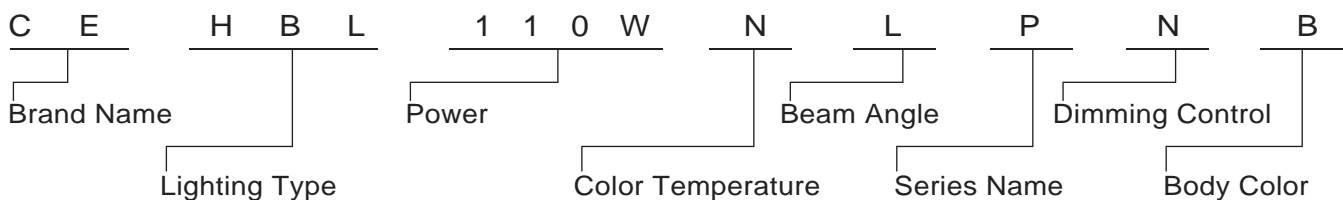

Brand Name	Lighting Type	Power	Color Temperature	Beam Angle	Series Name	Dimming Control	Body Color
CE: CELEX	HBL: High Bay Light	110W 120W	W: 3000K N: 4000K D: 5000K C: 6500K	S: 25° M: 45° L: 60° X: 90° W: 100°	P: PRO Series	D: DMX 512 N: Switch In (ON / OFF) T: Triac Leading Edge V: 0~10V Dimming A: Dali	B: Matte Black S: Matte Silver