

# LED Down Light PRO I Series

(Adjustable and Recessed Type)

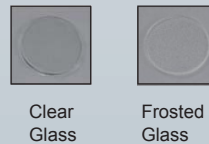

## Product Dimensions:

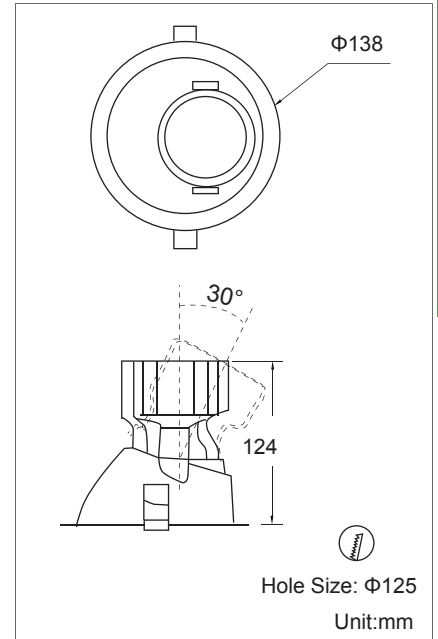

## Luminous Intensity Distribution Diagram:

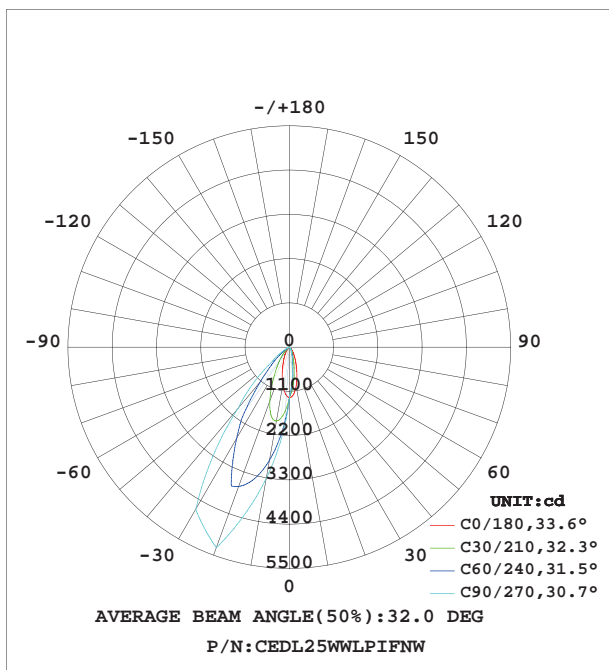

## Lux Distribution:

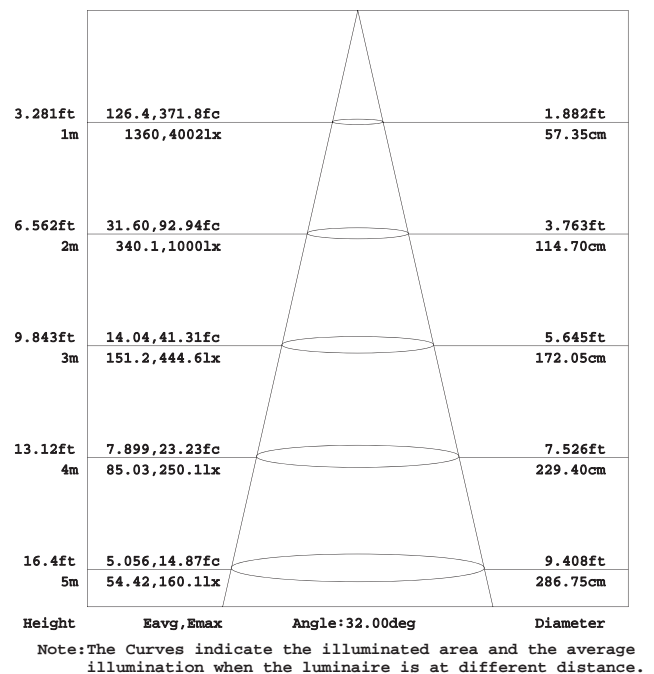

### Manufacturing Quality Standard:

- ISO 9001:2008
- EN/IEC 60598-1
- EN/IEC 60598-2-1
- EN/IEC 60598-2-2
- EN/IEC 60529
- EN/IEC 62471-2
- IEC 62612
- EN/IEC 60968
- IEC 62560
- EN/IEC 60061-1
- EN 13032-1
- EN 13032-2
- EN/IEC 62471



### Electronic Driver Standard:

- EN/IEC 61347-1
- EN/IEC 61347-2-13
- EN/IEC 62384
- EN/IEC 61000-3-2
- EN/IEC 61000-3-3
- EN/IEC 61547
- EN 55015(CISPR 15)

### LED Module Standard:

- IEC 62031
- IEC 60838-2-2

### LED Light Photometric Standard:

- CIE; TM14; LM-75; IES; LDT; CEN; CIB

### RoHS Standard:

- EPA3050B
- EN 1122
- IEC 62321
- EPA3052
- EPA3060A
- EPA7196A
- EPA3540C
- EPA8270C

### LED Luminaire Performance:

- IESNA LM-79-08
- IESNA LM-80-08
- Switching cycle: 100,000x

### Emergency Standard:

- With CELEX-LED Emergency System
- HKFSD PPA 104A(4th Revision)
- EN 60598-2-22
- BS 6387
- BS EN 60598-2-22
- EN 61347-2-7
- BS EN 60702-2
- BS 5266-1
- BS 6207-3

# LED Down Light PRO I Series

(Adjustable and Recessed Type)



## Features:

- Recess mounted and adjustable type
- Die casting aluminum
- Static spray coating surface
- Unique fin design
- Uniform illumination with special aluminum reflector
- High power efficiency (>0.85) and power factor(>0.9)
- Remote-type LED driver
- Optional 1~10V driver for dimming control
- Optional dali driver for dimming control
- Optional DMX driver for dimming control
- Optional battery kit for emergency lighting
- Optional DMX driver for DMX512 dimming control

## Applications:

- Home use
- Hotel Lounges
- Restaurants
- Halls and clubs
- Ballrooms



## Specifications:

|                           |  |
|---------------------------|--|
| Power                     | 25W  |
| Light Source              | Bridgelux  |
| Beam Angle                | 15°/24°/ 36°   |
| Cover Diffuser            | Clear Glass / Frosted Glass  |
| Power Factor              | >0.9   |
| Input Voltage             | AC 220~240V 50/60Hz or AC100~240V 50/60Hz  |
| Total Harmonic Distortion | <20%   |
| Color Rendering Index     | 80   |
| Luminaire Efficacy        | 70lm/w(2700K),75lm/w(3000K),85lm/w(4000K), 90lm/w(5000K), 100lm/w(6500K)         |
| LED Source Efficacy       | 95lm/w (2700K), 100lm/w (3000K),110lm/w (4000K),115lm/w (5000K), 125lm/w (6500K) |
| Life Time                 | 50,000 Hours   |
| Operating Temperature     | -20°C~50°C   |
| Operating Humidity        | 10%~90%RH  |
| Finishing Materials       | Aluminum and Safety Glass  |
| Trim Color                | Matte White / Matte Black  |
| RAL Color Code            | RAL 9003 / RAL9005   |
| Net Weight                | 0.4kg  |

## Ordering Part No.:

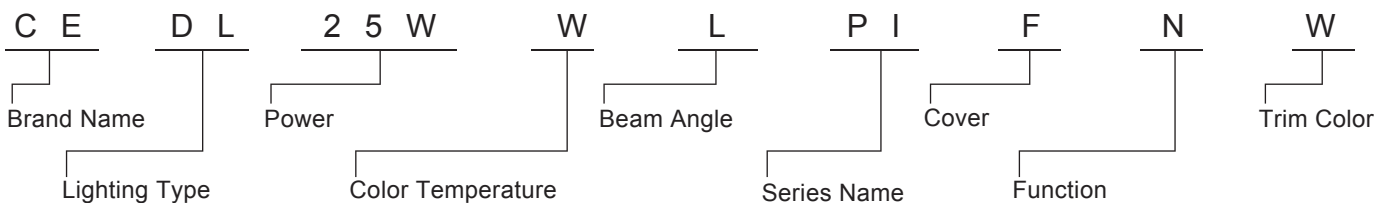

| Brand Name   | Lighting Type     | Power | Color Temperature  | Beam Angle                 | Series Name         | Cover Diffuser                           | Function   | Trim Color                             |
|--------------|-------------------|-------|--|----------------------------|---------------------|--|--|--|
| CE:<br>CELEX | DL:<br>Down Light | 25W   | O: 2700K<br>W: 3000K<br>N: 4000K<br>D: 5000K<br>C: 6500K | S: 15°<br>M: 24°<br>L: 36° | PI:<br>PRO I Series | C:<br>Clear Glass<br>F:<br>Frosted Glass | D:DMX 512 Dimming<br>E:Emergency(3hrs)<br>N:Switch In<br>T:Triac Dimming<br>Leading Edge<br>V:1~10V Dimming<br>I: Dali Dimming | W:<br>Matte White<br>B:<br>Matte Black |