

Product Dimensions:

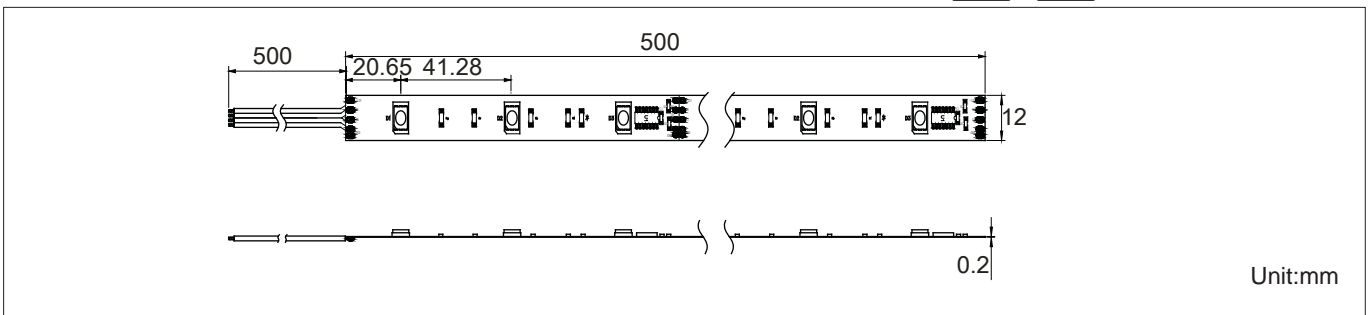

Luminous Intensity Distribution Diagram:

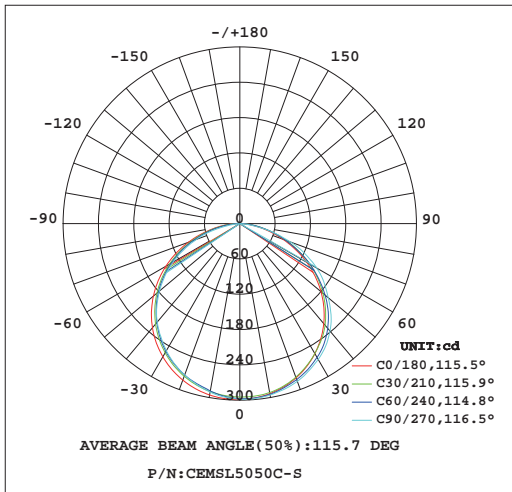

Lux Distribution:

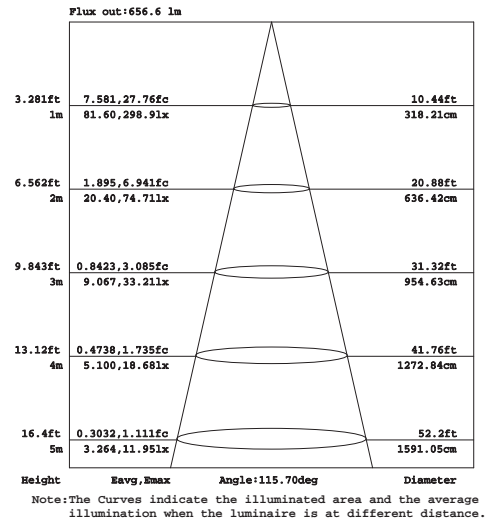

Manufacturing Quality Standard:

- ISO 9001:2008

LED Luminaire Standard:

- EN/IEC 60598-1
- EN/IEC 60598-2-1
- EN/IEC 60598-2-2
- EN/IEC 60529
- EN/IEC 62471-2
- IEC 62612
- EN/IEC 60968
- IEC 62560
- EN/IEC 60061-1
- EN 13032-1
- EN 13032-2
- EN/IEC 62471
- EN/IEC 60825
- EN 60061-1

Electronic Driver Standard:

- EN/IEC 61347-1
- EN/IEC 61347-2-13
- EN/IEC 62384
- EN/IEC 61000-3-2
- EN/IEC 61000-3-3
- EN/IEC 61547
- EN 55015(CISPR 15)

LED Module Standard:

- IEC 62031
- IEC 60838-2-2

RoHS Standard:

- EPA3050B
- EN 1122B
- IEC 62321
- EPA3052
- EPA3060A
- EPA7196A
- EPA3540C
- EPA8270D

LED Luminaire Performance:

- Switching cycle:100,000x

LED Light Photometric Standard:

- CIE; TM14; LM-75; IES; LDT; GEN; CIB

Features:

- Life of LED:50,000 hours
- UV and IR free
- Excellent cooling system
- Green and eco-friendly without mercury
- Energy-saving

Applications:

- Entertainment
- News conference venues
- Shops, shopping malls



Specifications:

Part No	Color	LED Q'ty	Power Conx.	Flux/m	Flux/Roll	View Angle	Size
CEMSL5050W-S	2800±200K	24PCS/M	24W/Roll	360lm	1250±50lm	140°±5°	5m/Roll
CEMSL5050N-S	4000±200K	24PCS/M	24W/Roll	385m	1325±50lm	140°±5°	5m/Roll
CEMSL5050C-S	6000±200K	24PCS/M	24W/Roll	400lm	1425±50lm	140°±5°	5m/Roll
CEMSL5050R-S	Red (620-630nm)	24PCS/M	24W/Roll	75lm	375±30lm	140°±5°	5m/Roll
CEMSL5050Y-S	Yellow (584-595nm)	24PCS/M	24W/Roll	100lm	500±30lm	140°±5°	5m/Roll
CEMSL5050G-S	Green (512-530nm)	24PCS/M	24W/Roll	75lm	375±30lm	140°±5°	5m/Roll
CEMSL5050B-S	Blue (460-475nm)	24PCS/M	24W/Roll	75m	375±30lm	140°±5°	5m/Roll
CEMSL5050RGB-S	RGB	24PCS/M	24W/Roll	120lm	600±30lm	140°±5°	5m/Roll

Products Characteristic:

- Input Voltage: DC 12V
- Operating Temperature: -20°C ~ 50°C
- Humidity: 0~95%
- Color:Colorful
- LED Life: 50,000 hours (Ta=20°C)
- Materials: Gu & Silica Gel Cover
- LED Type: SMD5050
- Dimension:5000*12*0.2mm



Electric parameter

Driving method Constant Voltage DC12V

Wires & Series connection length

Wires Input end connect Four-core RW R/G/B&Black wire

Stand length in serial connection 5M

Maximum length in serial connection 5M

Fixed mode

Screw

Double-sided adhesive 5000*10mm,3M double side adhesive tape

Power Connection Method

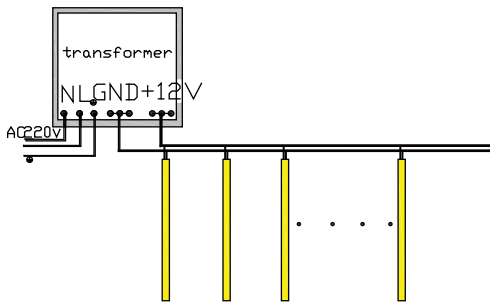

RGB Control System

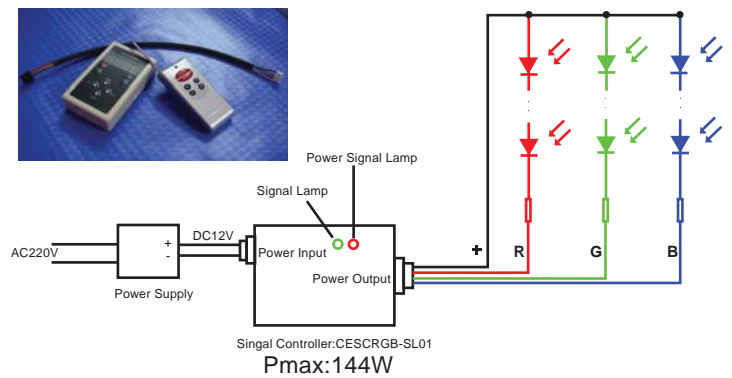

Fixed mode

Screw

Double-sided adhesive 5000*12mm,3M double side adhesive tape

