

SHO



# Courtyard Light

- Material and features:
  - \* Protection index:IP65
  - \* Power supply parameter:220V+10V/50Hz~60Hz
  - \* Head type:E27/G12
  - \* Recommended height(m):3.5~4.5 metres
  - \* Characteristics of lamps:die-cast aluminum alloy body
  - \* Canister-shaped PC lampshade with strong diaphaneity
  - \* The surface is coated with outdoor powder,smooth acid and alkali resistant,aging resistant
- Applications:Square,parks,residential areas,pedestrian precincts,etc.



## Product Dimensions:

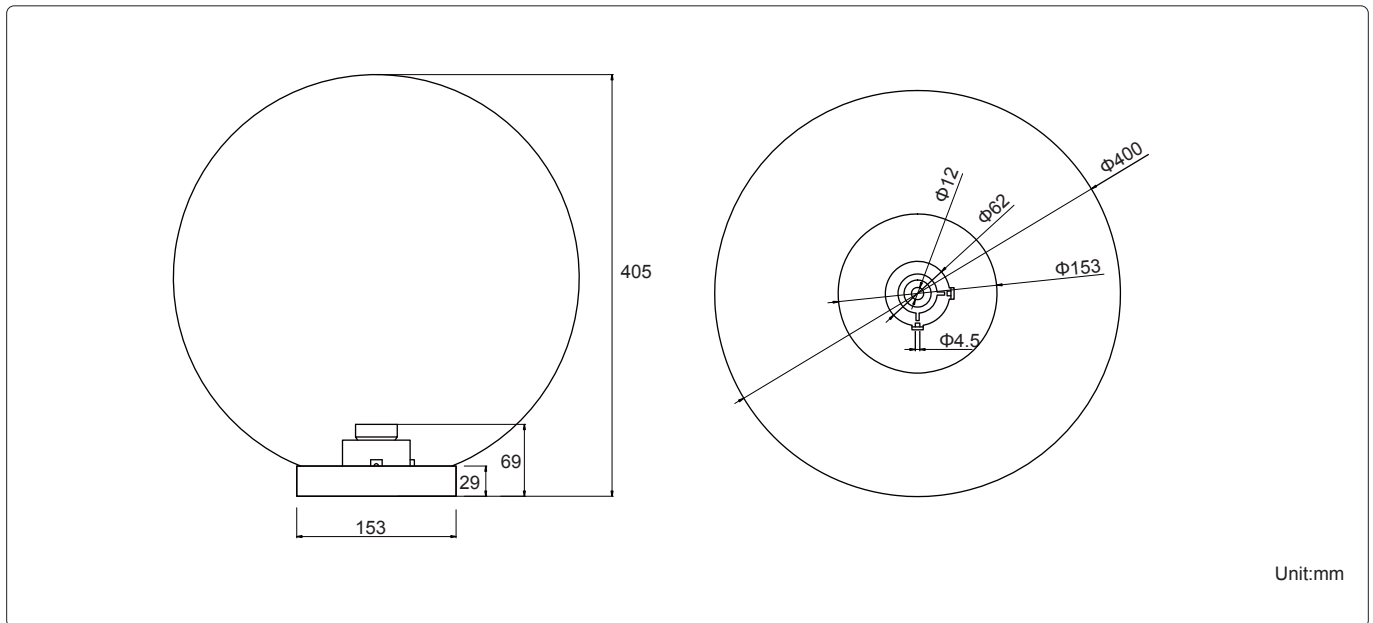

## Luminous Intensity Distribution Diagram & Lux Distribution:

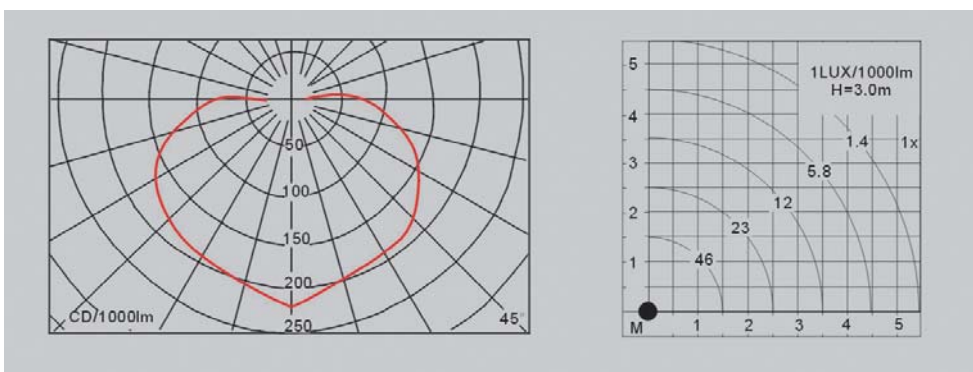

**Manufacturing Quality Standard:**

• ISO 9001:2008

**Light Photometric Standard:**

• CIE; TM14; LM-75; IES; LDT; CEN; CIB